

SMART HOPPER OPERATIONS MANUAL

INTELLIGENCE IN VALIDATION





CONTENTS

1 Introduction	4
2 Technical Specification	6
3 General Description	7
4 Installation	9
4.1 Hopper Installation	9
4.2 Lock Installation	10
5 Machine Interfaces	11
5.1 Status LEDs	11
5.2 Hardware	12
5.2.1 Connection Diagram	13
5.2.2 Interface Connector	13
5.3 Communication Protocols	14
5.3.1 Encrypted SSP (eSSP)	14
6 Programming the SMART Hopper	15
7 Maintenance	16
7.1 Clearing a Jam	16
Appendix A – Ordering Information	17
Appendix B – Dimension Drawing	18
Appendix C – eSSP Commands	19
Appendix D – Example eSSP Communications	20
Appendix E – Parts List	22
Revision History	23

TABLES

Table 1 - Environmental Requirements	6
Table 2 - Power Requirements	6
Table 3 - Interface Logic Levels	6
Table 4 - Maximum and Minimum Coin Dimensions	6
Table 5 - Approximate Hopper Capacities	6
Table 6 - SMART Hopper Weights	6
Table 7 - LED Status Codes	11
Table 8 – eSSP Host Connector Pin Details	13
Table 9 - CCT Coin Acceptor Connections	13
Table 10 - SMART Hopper eSSP Commands	19
Table 11 - eSSP example for the SMART hopper with coin mech connected via the hopper	20
Table 12 – eSSP example for the SMART hopper with coin mech connected separately	21

FIGURES

Figure 1 - SMART Hopper Connection Diagram	13
Figure 2 - Interface Connections location	13
Figure 3 - Connecting the SMART hopper to a PC	15

1 INTRODUCTION

This manual describes the operation of the SMART Hopper programmed with version SH00026 firmware or later. As a result of Innovative Technology Ltd continuous improvement policies, some functions mentioned in this manual may be changed. New functions may also be added.

This document is intended for those who will

- Install the SMART Hopper
- Maintain the SMART Hopper

Although information is included in this document that will allow a degree of fault diagnosis and repair, it is recommended that for all but simple repairs, the unit must be returned to an approved service centre for repair.

CAUTIONS



- Never exceed the recommended environmental and electrical limits.
- Do not attempt to lubricate the mechanisms as this may affect the coin transport.
- Always ensure power is removed from the hopper before carrying out any work.

WARNING

- Only suitably trained personnel should carry out any work on this equipment in accordance with all current local, national and international health and safety regulations.

We recommend that you study this manual as there are many new features permitting new uses and more secure applications. If you do not understand any part of this manual please contact your local office for assistance, contact details are available from www.innovative-technology.co.uk. In this way we may continue to improve our product.

Innovative Technology Ltd has a policy of continual product improvement. As a result the products supplied may vary from the specification described here.

MAIN HEADQUARTERS	<p>Innovative Technology Ltd Derker Street – Oldham – England - OL1 4EQ Tel: +44 161 626 9999 Fax: +44 161 620 2090 E-mail: support@innovative-technology.co.uk Web site: www.innovative-technology.co.uk</p>
<p>GROUP</p>   	<p>EMAIL CONTACT</p> <p>BRAZIL suporte@bellis-technology.com.br</p> <p>CHINA support@innovative-technology.co.uk</p> <p>COLOMBIA support@automated-transactions.net</p> <p>GERMANY support@automated-transactions.de</p> <p>ENGLAND support@innovative-technology.co.uk</p> <p>SPAIN soporte@automated-transactions.es</p> <p>UNITED STATES OF AMERICA supportusa@bellis-technology.com</p> <p>REST OF THE WORLD sales@innovative-technology.co.uk</p>

2 TECHNICAL SPECIFICATION

ENVIRONMENT

Environment	Minimum	Maximum
Temperature	+3°C	+50°C
Humidity	5%	95% Non condensing

Table 1 - Environmental Requirements

POWER REQUIREMENTS

Electrical Supply	Minimum	Maximum
Supply Voltage (V DC)	+20 V	+28 V
Absolute Limits		
Supply Ripple Voltage	0 V	0.25 V @ 100 Hz
Supply Currents		
Standby		TBC - Approximately 100mA
Running		TBC - Approximately 3 to 5A
Peak (Motor Stall)		TBC - Approximately 5A

Table 2 - Power Requirements

Interface Logic Levels	Logic Low	Logic High
Inputs	0V to +0.5V	+3.7V to +12V
Outputs with 2K2Ω pull up	0.6V	Pull up voltage of host interface
Maximum Current Sink	50mA per output	

Table 3 - Interface Logic Levels

COIN DIMENSIONS

Coin Parameter	Minimum	Maximum
Diameter	18mm	28.5mm
Thickness	1.65mm	3.3mm

Table 4 - Maximum and Minimum Coin Dimensions

CAPACITY

The capacity of the SMART Hopper depends on the size of coins. The table below shows approximate capacity for various coins and assumes all the coins within the hopper are the same type

Coin Type	Diameter	Thickness	Approximate Capacity
UK £1	22.5mm	3.15mm	1300
UK £2	28.4mm	2.5mm	800
Euro €1	23.25mm	2.33mm	1500

Table 5 - Approximate Hopper Capacities

WEIGHT

Coin Type	Coin Weight	Total Weight
Empty	-	2.40 kg
UK £1	9.5g	~ 14.75kg when full (1300 Coins)
UK £2	12.0g	~ 12kg when full (800 Coins)
Euro €1	7.5g	~ 13.65kg when full (1500 Coins)

Table 6 - SMART Hopper Weights

3 GENERAL DESCRIPTION

The Innovative Technology SMART Hopper sets new standards for coin handling technology. The SMART Hopper is a multi-coin hopper with the ability to payout coins of 11 different denominations at speeds up to 12 coins per second.

TRADITIONAL SETUP

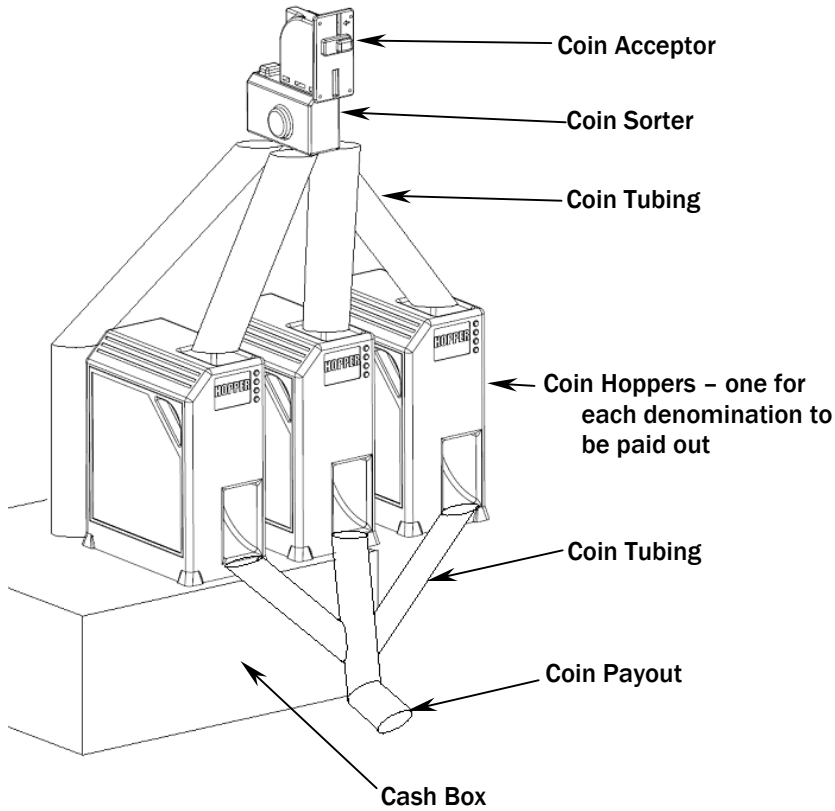

SMART HOPPER SETUP

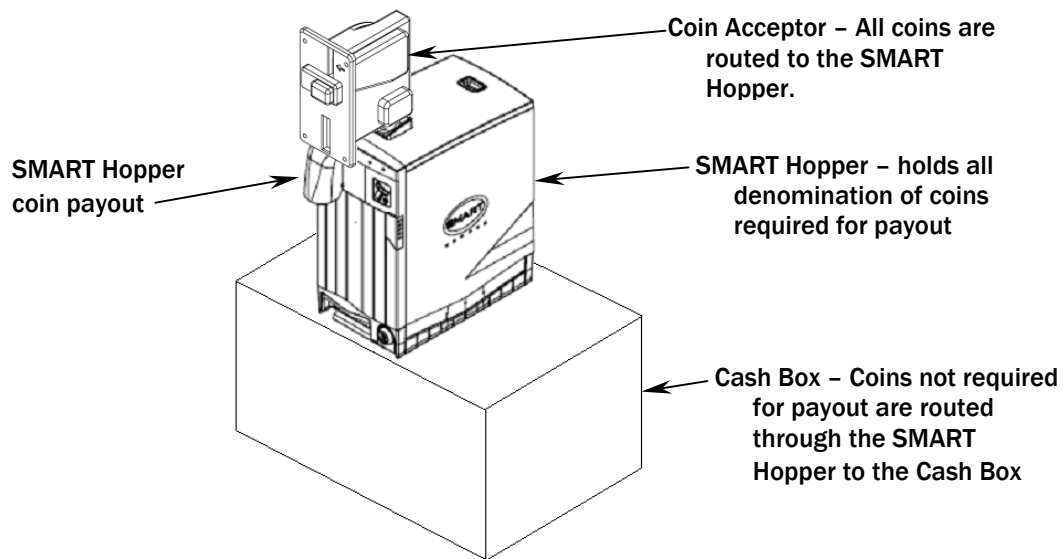

Other Features Include: -

- **Floating function**– When the hopper receives the command to float to a required level, coins are sent to the cash box until the requested float level remains in the hopper
- **No need for additional sorters, hoppers or tubing** – all coins validated by the coin mechanism enter the hopper. The hopper will then send coins not required for future payments to the cash box.
- **Built in security** – Lid removal sensors; modulated coin exit sensor; 128 bit AES Encrypted SSP communications (eSSP); locking option.
- **The SMART Hopper can be used to control a coin acceptor** making machine wiring and software implementation simpler. There is no need to have a separate ccTalk bus to control the coin acceptor. Only 1 SSP bus is required, the hopper then communicates with the coin acceptor using a ccTalk connection.

4 INSTALLATION

4.1 HOPPER INSTALLATION

1. Secure the mounting plate using the 6 fixing holes shown in Appendix B – Dimension Drawing.
2. Connect the cable from the host machine to the connector on the rear of the mounting plate. See Chapter 5.2.2 - Interface Connector for connection details.
3. Slide the hopper onto the base plate; ensuring the hopper is fully pushed into position.
4. Apply power to the machine.

NOTES ON SAFETY

- Do not put a hand into the hopper while power is applied.
- It is possible for a static charge to be transferred onto the coins during normal operation. The coins should be discharged to earth before they are accessible to the user.

4.2 LOCK INSTALLATION

The SMART Hopper has the option to add a lock that prevents the hopper being removed from the mounting plate. The hopper uses a standard lock PA650 which includes all the parts shown with an asterisk *

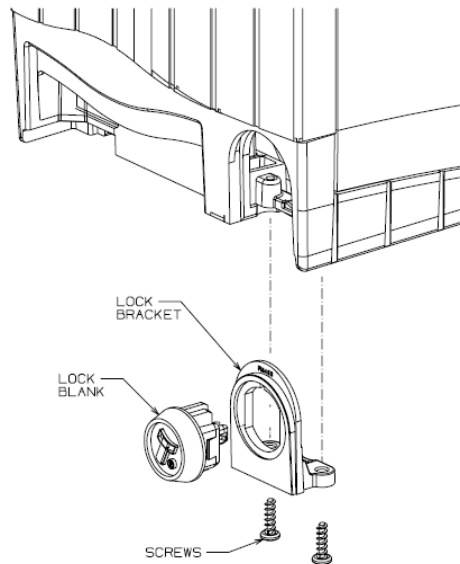

Remove the two screws from the base of the unit, and unclip the Lock Bracket as shown

Unclip the Lock Blank from the Lock Bracket

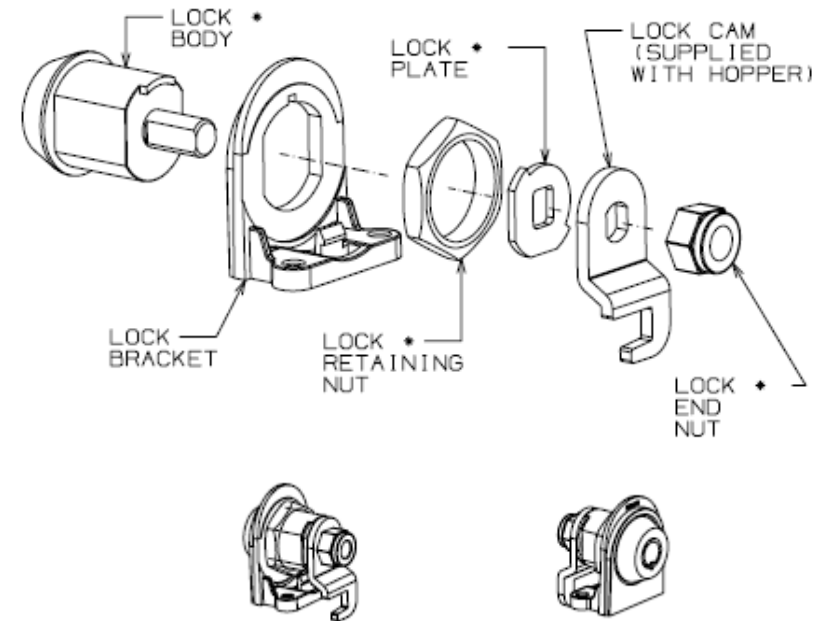

Assemble the lock in the order shown paying close attention to the orientation of parts

Place the Lock Bracket over the Lock Body and secure with the Retaining Nut
Place the Lock Plate and Lock Cam over the shaft of the Lock Body and secure with the Lock End Nut

Fit the assembly to the base of the hopper unit and secure with the two screws.
(The Lock Blank is no longer required)

5 MACHINE INTERFACES

5.1 STATUS LEDS

The SMART Hopper has 2 status LED's located on the front panel, one Green, one Red. The green status LED indicates system health, while the red status LED is used to indicate system problems; these are described below in Table 7 - LED Status Codes. The red LED will flash a number of times according to the status, pause and then flash the code again.

LED Colour	Status	Description
Green	Flashing (1Hz)	Heartbeat - System normal
Red	1 flash	Hopper disabled
	2 flashes	Calibration Fault
	3 flashes	No Encryption Key set
	4 flashes	Coin Jam
	5 flashes	Fraud Attempt Detected
	6 flashes	Hopper Empty
	7 flashes	Memory Checksum Error
	8 flashes	Hopper sensors are not Initialised
	9 flashes	Lid Removed

Table 7 - LED Status Codes

5.2 HARDWARE

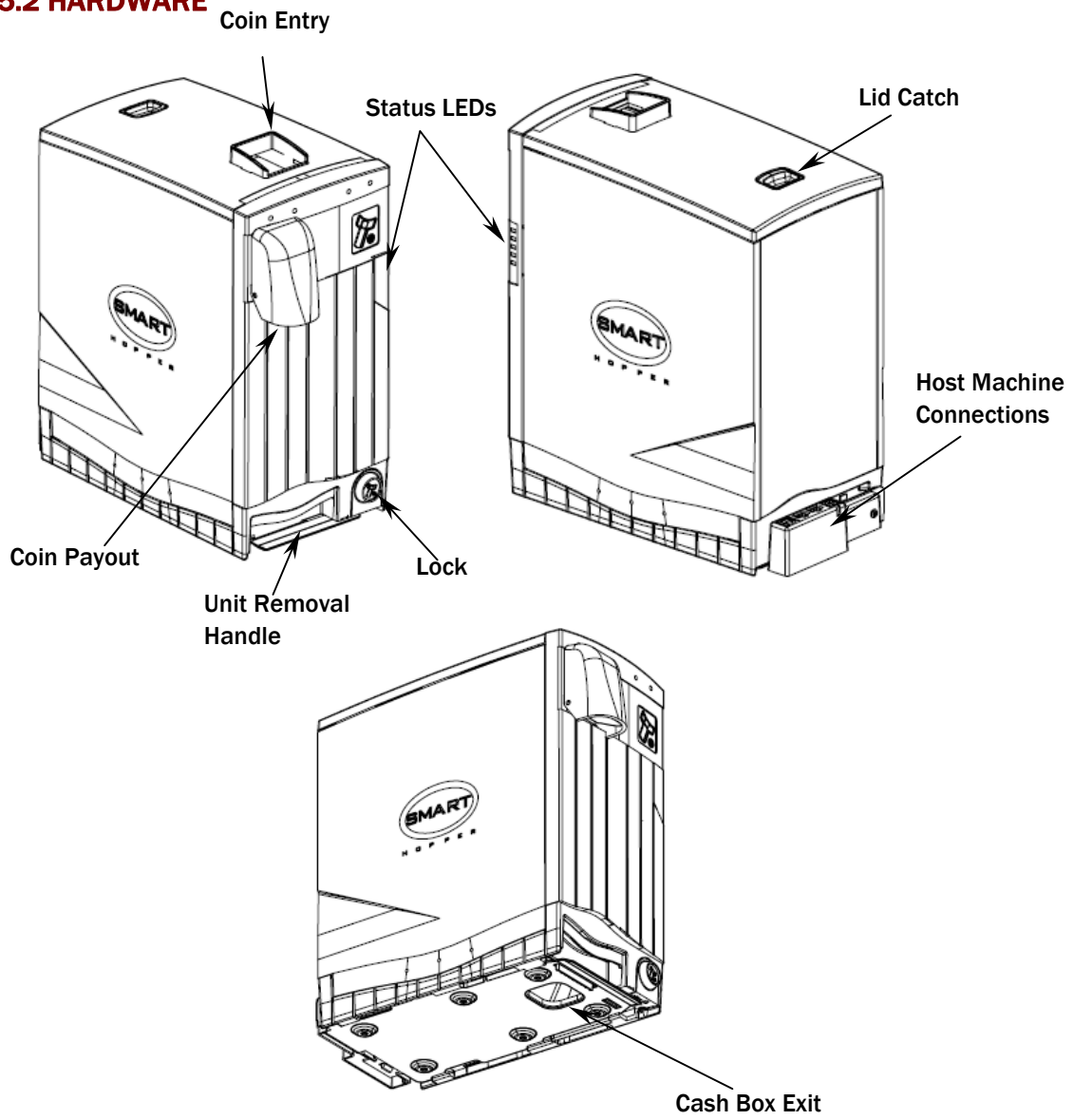

5.2.1 CONNECTION DIAGRAM

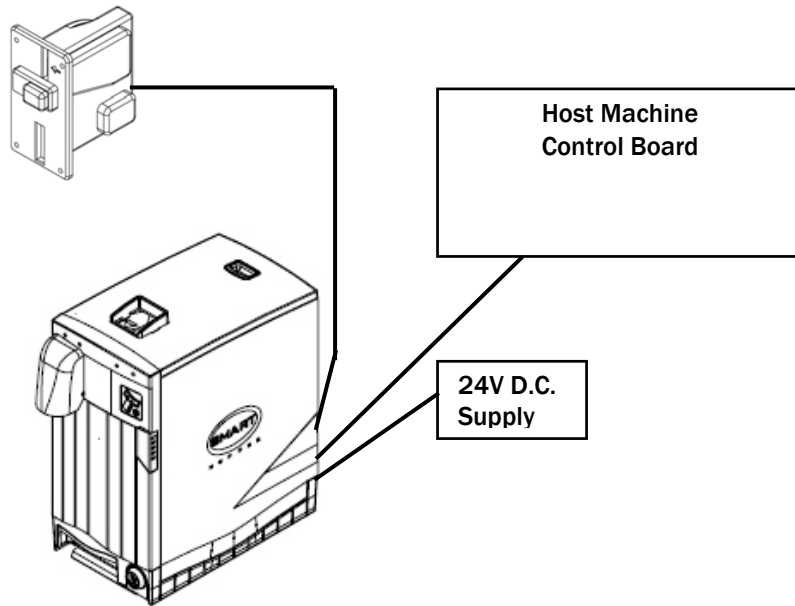

Figure 1 - SMART Hopper Connection Diagram

5.2.2 INTERFACE CONNECTOR

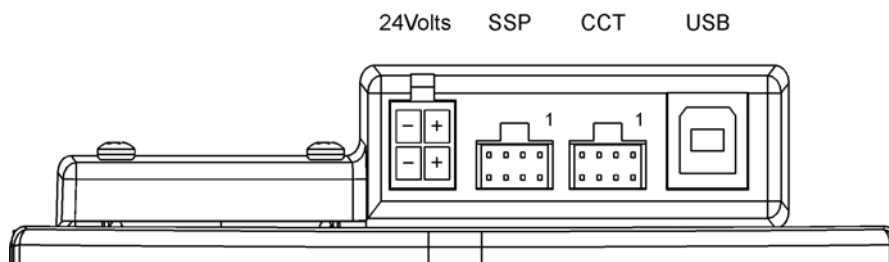

Figure 2 - Interface Connections location

eSSP Connections (Host Machine)

Pin	Function
1	eSSP Tx
2	eSSP Rx
8	Comms GND

Table 8 - eSSP Host Connector Pin Details

CCT Connections (coin acceptor)

Pin	Function
1 and 2	Data
7	+12V
8	0V

Table 9 - CCT Coin Acceptor Connections

The USB port can be used for eSSP communications in place of the eSSP Connector. Power must be supplied via the 4-way 24 Volt connection

5.3 COMMUNICATION PROTOCOLS

5.3.1 ENCRYPTED SSP (eSSP)

eSSP is a secure serial interface specifically designed to address the problems experienced by cash systems in gaming machines. Problems such as acceptor swapping, reprogramming acceptors and line tapping are all addressed.

The interface uses a master slave model, the host machine is the master and the peripherals (note acceptor, coin acceptor or coin hopper) are the slaves.

Data transfer is over a multi-drop bus using clock asynchronous serial transmission with simple open collector drivers. The integrity of data transfers is ensured through the use of 16 bit CRC checksums on all packets.

A Diffie-Hellman key exchange is used to allow the host machine and SMART hopper to jointly establish a shared secret key over an insecure communications channel. The encryption algorithm used is AES with a 128-bit key; this provides a very high level of security.

IMPORTANT: All transactions with the SMART Hopper must be encrypted to prevent dispense commands being recorded and replayed by an external device.

For detailed information and full protocol specification please refer to SSP Interface Specification (ITL Drawing GA138), this is available from the ITL website www.innovative-technology.co.uk.

For a list of SMART Hopper specific commands see Appendix C – ESSP Commands. Examples of communications between host machine and SMART Hopper are shown in Appendix D – Example ESSP Communications

6 PROGRAMMING THE SMART HOPPER

The SMART Hopper must be programmed with a dataset to recognise different currencies and denominations of coins. The Hopper will leave the factory pre-programmed with the required dataset, however it may be necessary to re-program the hopper as new coins are introduced or updates are made to the dataset. To program the SMART hopper a PC must be used running the ITL SMART Hopper Tools software version 1.70 or later.

Connect the hopper to the PC via a DA2 with cable assemblies CN385 and CN389 as shown in Figure 3 - Connecting the SMART hopper to a PC

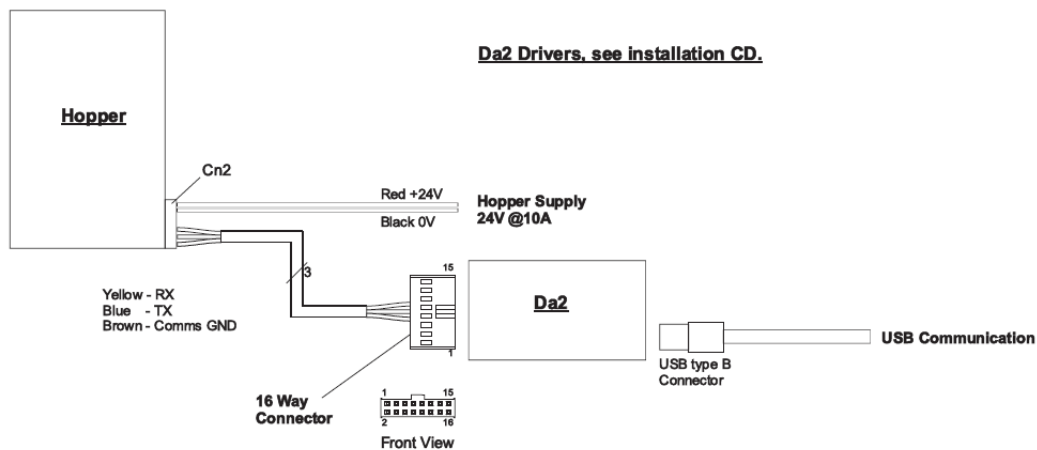

Figure 3 - Connecting the SMART hopper to a PC

Using the SMART Hopper Tools software, select update from the file menu and locate the required file. Once the file has loaded, click the 'Update Target' button to program the SMART Hopper.

7 MAINTENANCE

The SMART Hopper has been designed to minimise any performance variation over time. Much of this is achieved by careful hardware and software design.

7.1 CLEARING A JAM

On the unlikely event of a coin jamming within the SMART Hopper, follow the steps below

1. Power off the hopper
2. Remove the hopper from the mounting plate
3. Empty all coins from the coin bowl
4. Clear the jammed coin from the disk
5. Re-fit the hopper to the mounting plate
6. Re-fill the hopper
7. Apply power
8. Test operation

APPENDIX A – ORDERING INFORMATION

When ordering the SMART Hopper you will need to specify the currency required. For a list of available currencies, please visit www.innovative-technology.co.uk. The available currencies can be found under 'Support - Currency Downloads'

APPENDIX B - DIMENSION DRAWING

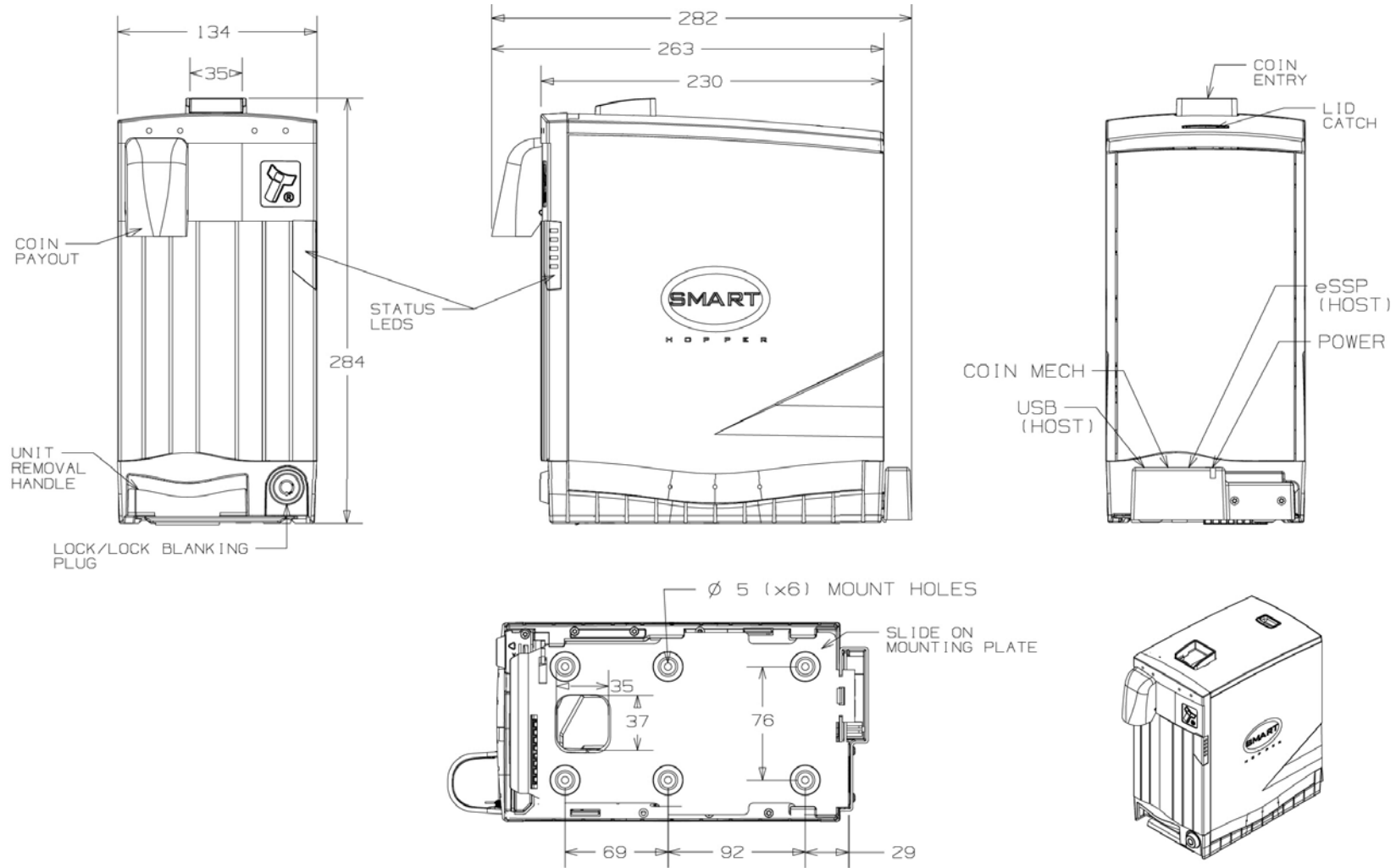

APPENDIX C – eSSP COMMANDS

Table 10 - SMART Hopper eSSP Commands shows the eSSP commands for the SMART Hopper. These commands are in addition to the Generic commands. See document number GA138 for the full eSSP specification. Commands marked with an asterisk (*) must be encrypted

Action	Command Code (HEX)
Get Device Setup	0x05
Payout Amount(*)	0x33, value
Set Coin Amount(*)	0x34, number, value
Get Coin Amount	0x35, value
Halt Payout(*)	0x38
Set Coin Routing(*)	0x3B, route, value
Get Coin Routing(*)	0x3C, value
Float(*)	0x3D, min payout, float value
Get Minimum Payout	0x3E
Set Individual Coin Accept Inhibit(*)	0x40, state, value
Empty(*)	0x3F
Host Serial Number Request(*)	0x14, Serial N°

Table 10 - SMART Hopper eSSP Commands

Get Device Setup: Single byte command used to request information about the hopper.

Payout Amount: Five-byte command to set the value to payout.

Set Coin Amount: Five-byte command used to inform the hopper of coins being added.

Get Coin Amount: Five-byte command that returns the coin count for a given value.

Set Coin Routing: Six-byte command to set the routing of each coin value. Coins can either be routed to the cash box, or recycled and used for payouts.

Set Coin Routing: Five-byte command that returns the routing for a given value

Float: Seven-byte command that sets the minimum payout value and the value to float to

Get Minimum Payout: Single byte command that returns the minimum payout value.

Set Individual Coin Accept Inhibit: Four-byte command that is used to enable or disable acceptance of individual coin values from a coin acceptor connected to the hopper.

Empty: This command will route all coins to the cash box without reporting any value and reset all the stored coin counters to zero.

Host Serial Number Request: Allows the host machine to send its serial number to the hopper. This may be used as an extra check that the host is authentic.

APPENDIX D – EXAMPLE eSSP COMMUNICATIONS

For more details on generating the encryption key, refer to the SSP Protocol specification, document number GA138

Host	Slave	Comments
> SYNC	< OK	
> SET_GENERATOR, [64 bit prime number]	< OK	Set the encryption key generator
> SET_MODULUS, [64 bit prime number]	< OK	Set the encryption key modulus
> REQUEST_KEY_EXCHANGE, [64 bit host intermediate key]	< OK, [64bit slave intermediate key]	Host sends the host intermediate key, the slave responds with the slave intermediate key. The encryption key is then calculated independently by both the host and the slave.
> GET_SERIAL	< OK < [SERIAL NUMBER]	
> GET_DEVICE_SETUP	< OK < [SETUP INFORMATION]	
> GET_COIN_AMOUNT, 0A 00 00 00	< OK < 2c 01	300 coins of 0010 value
> GET_COIN_AMOUNT, 14 00 00 00	< OK < 00 96	150 coins of 0020 value
> SET_ROUTING, 01 0A 00 00 00	< OK	Route coins of value 0010 to the cash box
> SET_ROUTING, 00 14 00 00 00	< OK	Recycle coins of value 0020 for future payouts
> SET_COIN_ACCEPT_INHIBIT, 00 01 00	< OK	Set the coin mech to Inhibit the acceptance of coins of value 0001
> SET_COIN_ACCEPT_INHIBIT, 01 14 00	< OK	Set the coin mech to accept coins of value 0020
> ENABLE	< OK	
> POLL	< OK	
> POLL	< OK	
> POLL	< OK, COIN_CREDIT, 0100	Credit from coin mech of 0100 value
> POLL	< OK	
> POLL	< OK, COIN_CREDIT, 0050	Credit from coin mech of 0050 value
> POLL	< OK	
> PAYOUT_AMOUNT, 28 00 00 00	< OK	Payout a value of 0040
> POLL	< OK < DISPENSING, 14 00 00 00	Currently dispensed 0020
> POLL	< OK < DISPENSED, 28 00 00 00	Dispense value of 0040 completed
> POLL	< OK	

Table 11 - eSSP example for the SMART hopper with coin mech connected via the hopper

Host	Slave	Comments
> SYNC	< OK	
> SET_GENERATOR, [64 bit prime number]	< OK	Set the encryption key generator
> SET_MODULUS, [64 bit prime number]	< OK	Set the encryption key modulus
> REQUEST_KEY_EXCHANGE, [64 bit host intermediate key]	< OK, [64bit slave intermediate key]	Host sends the host intermediate key, the slave responds with the slave intermediate key. The encryption key is then calculated independently by both the host and the slave.
> GET_SERIAL	< OK < [SERIAL NUMBER]	
> GET_DEVICE_SETUP	< OK < [SETUP INFORMATION]	
> GET_COIN_AMOUNT, 0A 00 00 00	< OK < 2c 01	300 coins of 0010 value
> GET_COIN_AMOUNT, 14 00 00 00	< OK < 00 96	150 coins of 0020 value
> SET_ROUTING, 01 0A 00 00 00	< OK	Route coins of value 0010 to the cash box
> SET_ROUTING, 00 14 00 00 00	< OK	Recycle coins of value 0020 for future payouts
> ENABLE	< OK	
> POLL	< OK	
> POLL	< OK	
> SET_COIN_AMOUNT, 03 00 32 00	< OK	3 coins of value 0050 added to hopper (total value of 0150)
> POLL	< OK	
> POLL	< OK	
> PAYOUT_AMOUNT, 28 00 00 00	< OK	Payout a value of 0040
> POLL	< OK < DISPENSING, 14 00 00 00	Currently dispensed 0020
> POLL	< OK < DISPENSED, 28 00 00 00	Dispense value of 0040 completed
> POLL	< OK	

Table 12 – eSSP example for the SMART hopper with coin mech connected separately

APPENDIX E – PARTS LIST

The following parts are available as spares

PA417 – SMART Hopper base plate

PA415 – SMART Hopper lid assembly

CN385 – SMART Hopper eSSP interface cable

CN389 – SMART Hopper power cable

CN214 – USB cable

PA650 – Lock

REVISION HISTORY

INNOVATIVE TECHNOLOGY LTD			
TITLE			
SMART HOPPER OPERATIONS MANUAL			
DRAWING NO			
GA401	AUTHOR		DATE
	RJS	26/03/09	FORMAT
			MS Word 2000
ISSUE	RELEASE DATE	MODIFIED BY	COMMENTS
1	30/06/09	RJS	Initial Release

Smiley® and the ITL Logo are international registered trademarks and they are the property of Innovative Technology Limited.

Innovative Technology has a number of European and International Patents and Patents Pending protecting this product. If you require further details please contact the factory. Innovative Technology is not responsible for any loss, harm, or damage caused by the installation and use of this product. This does not affect your local statutory rights. If in doubt please contact Innovative Technology for details of any changes.

In line with continued product development Innovative Technology Ltd. reserves the right to change specifications without prior notice. The data used in this document may be used as a guideline only.