

# Serial Universal Hopper Technical Manual



This document is the private unpublished property of Money Controls Ltd and may not be reproduced in part or in total by any means, electronic or otherwise, without the written permission of Money Controls Ltd. Money Controls Ltd does not accept liability for any errors or omissions contained within this document. Money Controls Ltd shall not incur any penalties arising out of the adherence to, interpretation of, or reliance on, this standard. Money Controls Ltd will provide full support for this product when used as described within this document. Use in applications not covered or outside the scope of this document may not be supported. Money Controls Ltd. reserves the right to amend, improve or change the product referred to within this document or the document itself at any time.

**Contents:**

**1. Diary of Changes ..... 4**

**2. Introduction..... 5**

**3. Mechanical Description ..... 5**

**4. Mechanical Features ..... 6**

    4.1 Hopper Dimensions ..... 6

    4.2 Hopper Weight..... 6

    4.3 Coin Size Range..... 6

    4.4 Coin Capacity ..... 6

**Overall Dimensions ..... 7**

**6. Installation and Removal ..... 8**

    6.1 Securing the hopper base..... 8

    6.2 Using the 4mm Holes ..... 8

    6.3 Dismantling the hopper..... 8

    6.4 Hopper Assembly ..... 8

**7. Why Serial ? ..... 9**

**8. Product Features ..... 10**

**9. ccTalk® Design Parameters ..... 12**

    9.1 Serial Connector Type ..... 13

        9.1.1 Serial Connector Pinout..... 13

    9.2 Address Selection..... 14

**10. Encryption Mechanism ..... 15**

    10.1 PIN Number Mechanism..... 17

**11. Power Fail Recovery..... 19**

    11.1 Power Fail in Detail..... 20

**12. What happens...? ..... 22**

    12.1 What happens after Power Up ?..... 22

    12.2 What happens after Software Reset ?..... 23

**13. Simple Coin Payout ..... 24**

**14. Full Initialisation & Payout Sequence ..... 25**

**15. Command List..... 28**

    15.1 Commands in Detail ..... 29

**16. Power Distribution on a Multi-Drop Bus..... 43**

**17. Electrical Noise - Physical Measures..... 44**

**18. Electrical Noise - Software Measures ..... 44**

**19. Electrical Specification ..... 45**

    19.1 Coin Payout: ..... 45

    19.2 Environmental:..... 45

**20. Maintenance Schedule ..... 46**

**21. Fault Finding and Repair..... 46**

**22. Appendix A..... 47**

    22.1 Conversion Equations & Default Values ..... 47

    22.2 Limits ..... 47

    22.3 Software Reset ..... 47

**23. Appendix B..... 48**

    23.1 Timing Parameters ..... 48

    23.2 Opto Security Timing ..... 48

    23.3 Hopper Initialisation ..... 48

**24. Appendix C..... 49**

    24.1 ccTalk® Interface Circuit ..... 49

**25. Appendix D..... 50**

    25.1 NV Memory Map Description..... 50

**26. Appendix E..... 52**

**Figures:**

Figure 1: Hopper Dimensions .....	7
Figure 2: SUH Connector .....	13
Figure 3: ccTalk® Interface Circuit: .....	49

**Tables:**

Table 1: Coin Capacities .....	6
Table 2: Address Selection .....	14
Table 3: Command List. ....	28
Table 4: Flag Action Table:.....	41
Table 5: Electrical Specification.....	45
Table 6: Coin Payout Rate .....	45
Table 7: Environmental Ranges .....	45
Table 8: Maintenance Schedule .....	46
Table 9: Fault Finding and repair.....	46
Table 10: Conversion Equations & Default Values:.....	47
Table 11: Timing Parameters: .....	48
Table 12: NV Memory Map Description:.....	50

# 1. Diary of Changes

Issue 1.0 First Issue.....2nd October 2002  
➤ Information based on SUH Product Manual V1.1

## 2. Introduction

The Universal Hopper with Serial Interface is a serially controlled version of the popular Universal Hopper manufactured by Money Controls. The serial interface is **cctalk**, firmly established as a leading, low-speed, device control protocol in the money-transaction industry. A key feature of cctalk is its optimal balance between simplicity and security.

## 3. Mechanical Description

Each hopper contains a coin track which consists of individual plates clipped together. The track is driven via gears from a motor. The track moves in an anti-clockwise direction (viewed from the end plate side). As the track moves, it picks coins up from the bottom of the cashbox and transports them to the coin exit window. The tracks are designed so that when the coin is adjacent to the coin exit, the coin rolls off the track, through the exit window and passed the optic sensors.

An optical coin detector is created by infrared transmitters and photo detectors situated on the PCB which is sited in the exit window. The infrared light beam is routed across the exit slot via a light guide. When a coin passes through the exit the light beam will be broken and a coin output signal will be generated.

Although the Universal Hopper is called 'Universal' there are a number of track options to overcome specific coins and coin ranges.

These are:-

Large coin =	(30.1 - 31.0 mm dia)
Standard coin track =	(21.0 - 30.0 mm dia)
Small coin track =	(17.5 - 20.9 mm dia)
Euro track =	(€2, €1, 50c, 20c, 10c, 5c)
Euro small coin =	(16.0 - 20.9 mm dia) - previously called the small thin coin.

## 4. Mechanical Features

### 4.1 Hopper Dimensions

The hoppers overall dimensions, mounting arrangement, coin entry and exit points are detailed in [Figure 1](#).

### 4.2 Hopper Weight

Empty = 1.87 Kg

### 4.3 Coin Size Range

Hoppers can be configured to pay out coins in the diameter range 16.0mm - 31.0mm, and within the thickness range 1.25mm - 3.50mm.

### 4.4 Coin Capacity

The coin capacity of the hopper is between 700 and 3500 depending on their physical size.

*Table 1: Coin Capacities*

Coin	Diameter (mm)	Thickness (mm)	SUH Capacity
£2	28.40	2.50	760
£1	22.50	3.10	940
50p new	27.30	1.80	1130
20p	21.40	1.80	1840
10p	24.50	1.83	1400
5p	18.00	1.73	2720
2p	25.90	1.80	1120
1p	20.25	1.43	2350

**Note: these capacities are subject to a +/- 10% error.**

### 5. Overall Dimensions

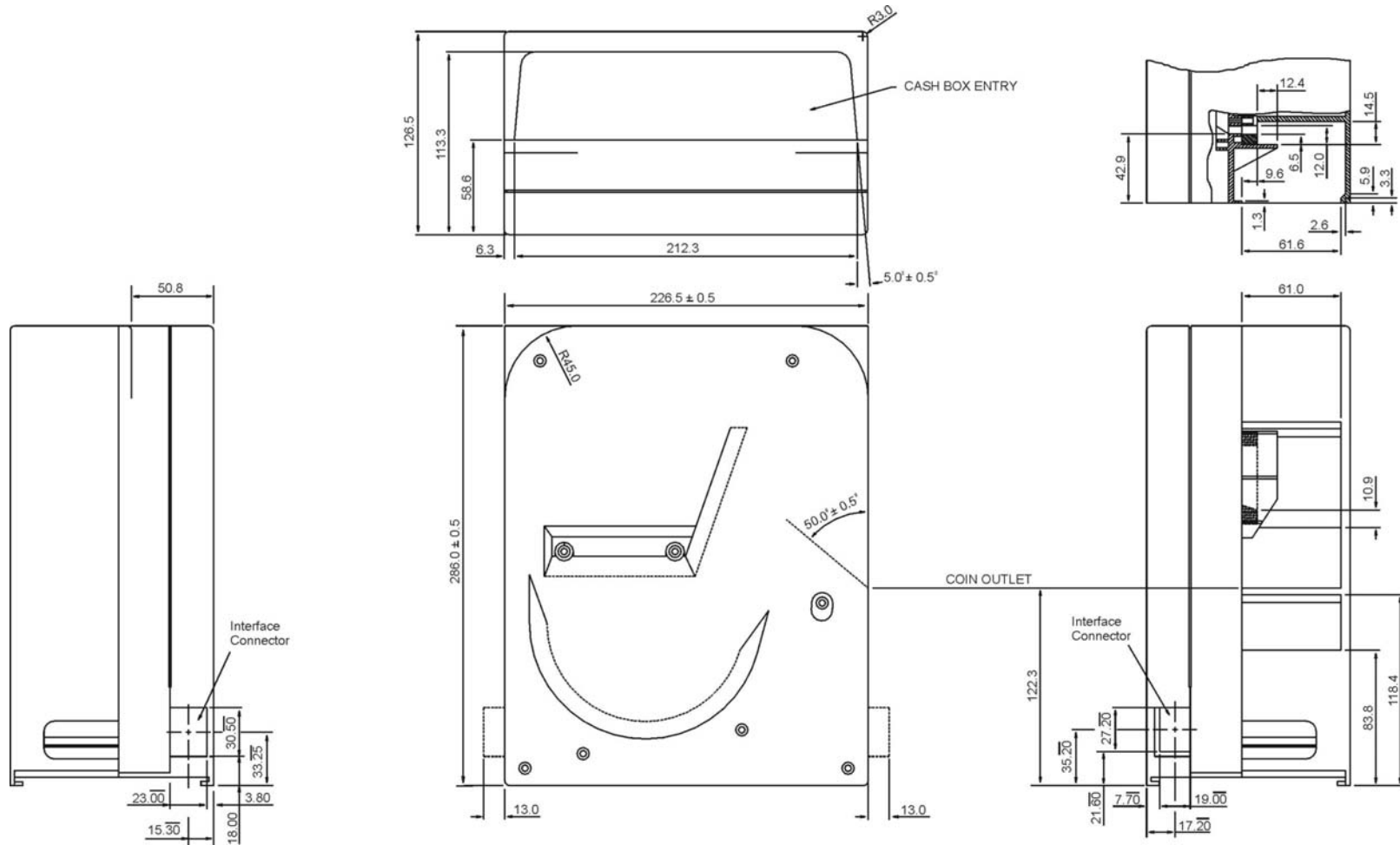

Figure 1: Hopper Dimensions

CONFIDENTIAL

Not to be disclosed without prior written permission from Money Controls

## 6. Installation and Removal

**Warning: Ensure that the power has been disconnected from the hopper before removal.**

### 6.1 Securing the hopper base

- A set of fixing holes have been provided in the baseplate to allow the hopper to be secured in a host machine.

### 6.2 Using the 4mm Holes

- Drill 6 holes on the centres
- Set the baseplate over holes and fix into position using M3 screws

### 6.3 Dismantling the hopper

- Please refer to the Universal Hopper Service Manual TSP053 for full details.

### 6.4 Hopper Assembly

- Please refer to the Universal Hopper Service Manual TSP053 for full details.

## 7. Why Serial ?

Coin hoppers traditionally have a simple parallel interface. Common methods for paying out coins include 'logic motor control' whereby a low voltage control signal can be used to turn the motor on and off, and 'pulse counting' whereby a stream of pulses is used to dispense the coins ( one coin per pulse ). In the 'logic motor control' method it is up to the host software to monitor and count coins travelling past the payout optics.

Serial gives immediate benefits for security as an encrypted dispense command is needed to pay out any coins from the hopper, and the hopper itself counts the coins coming out. The opportunities for an external attack are much reduced. It also reduces loading on the host controller - it can perform other tasks while the hopper is paying out coins.

Another benefit of 'multi-drop' serial is the ability to connect several coin hoppers to the same wiring harness or 'bus'. This greatly simplifies the cabling within a machine as multiple hoppers can be daisy-chained together rather than having to branch out from a central star point. The number of control signals is usually much less with serial than with parallel. The only control signal in the cctalk protocol is a single bi-directional 'data' line. It is also possible with serial to connect in other money transaction peripherals such as coin acceptors, bill validators and card readers.

The inherent 'expandability' of serial allows for a much better level of diagnostics and error reporting than is available on parallel, if it is available at all. Rather than a general alarm condition, the difference between a coin jam and a deliberate attempt to fraud the hopper can be reported externally.

## 8. Product Features

SUH represents to date the most sophisticated serial coin hopper in the world. Responding to comments from the leading UK machine manufacturers, Money Controls has designed in an unprecedented level of security.

The following features are available on SUH...

- Coin dispensing security. The serial command to pay out a coin uses a 64-bit encryption key which changes randomly after each operation. This makes serial 'cloning' whereby a handheld terminal listens to the serial bus and plays back dispense commands a fruitless exercise. A typical dispense cycle will see a total of 192 bits of random information transferred across the bus.
- Payout modes. The hopper defaults to multi-coin payout mode which pays up to 255 coins in a single dispense command. For extra security the hopper can be placed in single coin payout mode which only allows one coin to be paid out at a time.
- PIN number security. There is an option to protect the hopper with a PIN number so that if it is stolen from a machine and plugged into another one it cannot be made to work. It is the equivalent of a mechanical lock with the machine manufacturer generating and keeping the key.
- Opto security. During idling ( no coins being paid out ), the exit optos are randomly pulsed. If a blockage is seen while driving the opto or a short-circuit seen while not driving the opto then an alarm condition is generated. During pay out, if a short-circuit is seen while not driving the opto then an alarm is generated. Blockages are usually caused by inserting objects into the hopper exit and short-circuits by shining torches or lasers into the optics.
- Anti-jam operation. If the hopper experiences a coin jam during a payout sequence it will automatically reverse in order to clear the jam.
- Software fuse. If an absolute maximum current threshold is exceeded ( factory pre-set ) then the hopper aborts payout with an error code.
- Polyswitch protection. The motor driver terminals are protected with a polyswitch for additional overload protection.
- Power fail protection. A non-volatile memory keeps track of coins paid out. If power is lost during a payout sequence then the residual number of coins to pay can be read back after the machine re-initialises.
- Unique serial number. Each hopper is manufactured with a unique 24-bit serial number which cannot be modified by external means.
- Coin counting. Two counters record the number of coins paid out of the hopper. One is reset-able by the user, the other is a life counter. Both are implemented in NV Memory.
- Data integrity. All coin counter values in NV Memory are stored with a 8-bit checksum to ensure data integrity.
- Level plate support. There is an option to fit high or low level plates and the status of these can be read by the host machine on serial.

Continued...

---

CONFIDENTIAL

Not to be disclosed without prior written permission from Money Controls

Page 10 of 53

- Remote configuration. Motor parameters such as reversing current and payout timeout can be changed with serial commands. No changes to electronic components are required.
- Multi-drop operation. A number of serial hoppers can be connected to the same serial bus. Device addresses default to those determined by the wiring harness but they can be changed in software to any 8-bit value.
- User memory. 10 bytes of non-volatile memory are available for unrestricted use by the host machine. There are various security and auditing tasks which could be accomplished with this feature.
- Extensive command set. Host software can implement a small or large fraction of the full command set available depending on the application. Commands are available for inhibiting the hopper, reading the state of the exit optos, checking the software revision etc.
- Diagnostic and error reporting. Full access to diagnostic and error codes are made available over serial.
- Code protection. The software is protected with an internal, independent, watchdog circuit. A 'crash' in the software will result in a clean reset of code.

## 9. ccTalk<sup>®</sup> Design Parameters

Refer to issue 4.2 of the 'cctalk Serial Communication Protocol / Generic Specification' for an explanation of the protocol and its implementation on any platform.

This product is configured as...

**cctalk b96.p0.v24.a5.d0.c9.m0.x8.i1.r3**

In other words...

9600 baud / open-collector interface / +24V supply / +5V data /  
supply sink / connector type 9 / slave device / 8-bit checksum /  
implementation level 1 / spec. issue 3

The hopper can **only** operate at 9600 baud.

### 9.1 Serial Connector Type

**Peripheral connector :**  
Cinch R76-77848 12-way male

*Figure 2: SUH Connector*

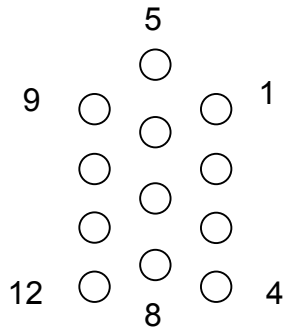

View of Connector from Front

#### 9.11 SERIAL CONNECTOR PINOUT

Pin	Function
1	0V
2	N.C.
3	N.C.
4	Address Select 1 - LSB
5	/DATA ( ccTalk <sup>®</sup> )
6	N.C.
7	N.C.
8	Address Select 2
9	+Vs
10	N.C.
11	N.C.
12	Address Select 3 - MSB

Operation can be achieved with just 3 wires...

- +24V to pin 9
- GND to pin 1
- Bi-directional serial data line to pin 5

## 9.2 Address Selection

The default ccTalk<sup>®</sup> bus address for a 'Payout' device is 3. This is the address of the Serial Universal Hopper if no connections are made to the address select pins (pins 1 to 3) on the connector.

For applications requiring more than one hopper on the serial bus, one or more of the address select lines may be connected to +Vs. A total of 8 unique bus addresses may be generated in this way, in the range 3 to 10 inclusive.

*Table 2: Address Selection.*

X = Connect to +Vs (Pins 4, 5)			Serial
Address select 3	Address select 2	Address select 1	Address
			3
		X	4
	X		5
	X	X	6
X			7
X		X	8
X	X		9
X	X	X	10

A number of mating connectors on a multi-drop bus cable may each be wired uniquely to allow operation of multiple hoppers. Since address selection is done externally, any Serial Universal Hopper may be plugged into any position on the bus and the host machine will know which one is paying out a particular coin.

Address determination from the connector is only done at power-up or reset. Changing the address select lines afterwards has no effect.

**Note : Addresses may be changed in software to values other than those in the above table. Refer to the 'Address change' and 'Address random' serial commands. These values are lost at power-down or reset.**

## 10. Encryption Mechanism

A 64-bit encryption mechanism is used to ensure that an illegal attempt to dispense coins from SUH is a hugely difficult task. The key to this mechanism is a secret algorithm, not published in this document, which may be obtained from Money Controls after suitable approval procedures have been gone through.

To show the procedure for dispensing a coin an example is shown here with a 'trivial' encryption mechanism but the overall procedure is the same. Byte values between brackets are shown in hex.

First of all we pump the random number generator of the hopper by sending 8 bytes of random data to it...

### Command = Pump RNG

Transmitted data : [ 34 ][ A2 ][ D7 ][ 0F ][ 35 ][ 17 ][ 55 ][ 94 ]  
Received data : ACK

This is not an essential step but is useful to broaden the spectrum of cipher keys that are transmitted along the serial bus and which may be 'recorded' by a hacker. As the host machine is likely to be an AWP machine with a sophisticated random number generator, way beyond the capability of the hopper microcontroller, we may as well make use of it. Note that the pump value does not pre-set or 'seed' the RNG as that would defeat the security mechanism, but only scrambles it further. The exact details of the scrambling algorithm will not be documented.

Then we request a key cipher key...

### Command = Request cipher key

Transmitted data : <none>  
Received data : [ E5 ][ 88 ][ 13 ][ 07 ][ 46 ][ FE ][ 29 ][ 05 ]

A new cipher key must always be requested prior to dispensing coins. There is no point using an old copy as it changes after every dispense command. The 'Request cipher key' command itself can be repeated in the event of a communication error and the cipher key will be re-transmitted rather than regenerated.

Now we combine the cipher key with the number of coins to pay out ( in this example 20 coins or the value 14 hex ) by tagging it onto the end of the data block...

Non-encrypted data [ E5 ][ 88 ][ 13 ][ 07 ][ 46 ][ FE ][ 29 ][ 05 ][ 14 ]

In this case we will assume that the CMF ( Cryptographic Mapping Function ) is simply inverting all the bytes ( new data = FF - old data ).

Performing this calculation on each of the bytes we obtain...

Encrypted data [ 1A ][ 77 ][ EC ][ F8 ][ B9 ][ 01 ][ D6 ][ FA ][ 14 ]

Note that the number of coins to pay out is unencrypted but its value is used in the real CMF.

Now we send that data to the hopper to pay out a coin...

Continued...

---

CONFIDENTIAL

## Command = Dispense hopper coins

Transmitted data : [ 1A ][ 77 ][ EC ][ F8 ][ B9 ][ 01 ][ D6 ][ FA ][ 14 ]

Received data : [ 5 ] - example event counter

The next time we pay out a coin the cipher key will have changed, so unless the algorithm is known, simple command 'cloning' will not work.

In practice, the CMF will be far more complex than this example and will require considerable computing power and a long observation period to 'crack'. Firing random data at the hopper will also prove fruitless as there are astronomical odds against a successful code match.

*Money Controls is realistic enough to appreciate that eventually the CMF may fall into the wrong hands whether through huge computing resource or through leaked documentation. We have embedded into our system an undocumented mechanism for changing the CMF in response to future industry needs without any change to hardware.*

An obvious hack would be to intercept and change the number of coins dispensed by the 'Dispense hopper coins' command to a greater value. This has been taken care of in the security algorithm and will not work.

## 10.1 PIN Number Mechanism

A PIN number is provided on SUH as an **optional** security feature. By default, units are shipped without the PIN number mechanism enabled. If this feature is not required or its use is too restrictive then it can simply be ignored.

By programming a PIN number into the device, if the hopper device is subsequently powered down or removed to another location then unless the PIN number is known, no coins can be dispensed. This is another layer of defence against the determined hacker who wishes to experiment with the encryption mechanism. However it does require the host machine keeping track of the PIN numbers of any hoppers used in that cabinet.

Various possibilities include...

### 1. Don't use a PIN number

Nice and easy that one.

### 2. Fix the PIN number to the same value always

This can be done but is not very secure. Once the PIN number is known then there is effectively no PIN number protection on any of the hoppers. It is simple to manage though and the 'master' PIN number is unlikely to be forgotten.

### 3. Scramble the PIN number and store in the user memory

This is quite a clever idea because it means you can randomise the PIN number on each hopper and as long as you know how you scrambled it, it can be recovered, unscrambled and sent to the hopper during the initialisation routine. Security relies on keeping this scrambling algorithm secret.

### 4. Log the PIN number versus serial number

As each hopper has a unique serial number then this gives a convenient method of storing the serial number against a random PIN number in a central database which all the machines have access too on a network. This is the most secure method because unless the PIN number transaction is captured on the bus at just the right moment in time, and for that particular hopper, the only way to obtain the PIN would be by exhaustive searching. With 4.3 billion combinations at 245ms per guess would take on average 16.7 years.

If you are unfortunate enough to have a hopper for which you have forgotten the PIN number then contact Money Controls for details of any possible recovery mechanism that we may have in place at the time.

Continued.....

---

CONFIDENTIAL

Not to be disclosed without prior written permission from Money Controls

Page 17 of 53

Example

This is how to set the PIN number on a new hopper to 1-2-3-4 which does not already have one...

**Command = Enter new PIN number**

Transmitted data : [ 1 ][ 2 ][ 3 ][ 4 ]  
Received data : ACK

Subsequent use of this command will still return an ACK but will not actually change the PIN number to any other value. This is a 'use once' command.

As soon as a PIN number is programmed, the 'Dispense hopper coins' command will fail until this PIN number is re-entered with the command below.

Likewise, after powering up SUH with the PIN number mechanism enabled, it must be entered prior to paying out coins.

**Command = Enter PIN number**

Transmitted data : [ 1 ][ 2 ][ 3 ][ 4 ]  
Received data : ACK

Note that an ACK is always returned, even if the PIN number is incorrect. This increases security.

## 11. Power Fail Recovery

SUH contains a non-volatile memory ( EEPROM ) for the storage of coin counters. Therefore if power is removed in the middle of a payout sequence then the situation can be recovered and the residual coins paid out after power is restored. This behaviour is under control of the host software - the hopper does not automatically dispense coins when power is re-applied.

The following counters are saved...

- [ Last payout : coins paid ] x 1 byte
- [ Last payout : coins unpaid ] x 1 byte
- [ Hopper dispense count ] x 3 bytes
- [ Hopper life dispense count ] x 3 bytes  
along with their corresponding checksums.

The [ Last payout : coins paid ] and [ Last payout : coins unpaid ] bytes can be read with the 'Request hopper status' command.

The [ Hopper dispense count ] can be read with the 'Request hopper dispense count' command.

The [ Hopper life dispense count ] can be read by looking at block 3 of the NV Memory using the 'Read data block' command. Refer to Appendix D for a memory map description.

After power-up initialisation, the host machine can read the [ Last payout : coins unpaid ] byte to determine if there are any remaining coins to be paid out after the last session. The decision to pay out any remaining coins is made by the host machine, not the hopper.

Continued...

---

CONFIDENTIAL

Not to be disclosed without prior written permission from Money Controls

Page 19 of 53

## 11.1 Power Fail in Detail

The sequence of saving the coin counters to NV Memory is triggered by the following conditions...

- Sudden loss of power with the motor running
- Receipt of an 'Emergency stop' command

If power is suddenly lost with the motor running then the hopper will stop the motor immediately and update the NV Memory while it has power to do so. SUH does not have a 'battery back-up' but uses a capacitor reservoir.

If power is lost after a payout sequence has completed ( hopper in idle ) then the [ Last payout : coins unpaid ] counter is cleared, regardless of the value it was holding. This is because it is assumed the host machine has dealt with the last payout sequence and taken appropriate action. It is not desirable to flag unpaid coins during the next power-up initialisation.

If the host machine has early notification of a power fail it can send an 'Emergency stop' command to the hopper. This command stops the motor dead and returns the number of unpaid coins back to the host. This value **should be stored by the host machine** prior to power being lost.

The use of the hardware reset line ( pin 10 of the connector ) is not to be used for aborting payout as this does not allow the coin counters to be saved. **The coin counters will be incorrect if the hardware reset pin is used during a payout sequence.**

Examples...

### a) Power lost during payout sequence

Counter	Initial value	Pay 3 from 10 then lose power
Last payout : coins paid	0	3
Last payout : coins unpaid	0	→7←
Hopper dispense count	0	3
Hopper life dispense count	N	N + 3

**Coins remaining = 7**

Continued...

CONFIDENTIAL

Not to be disclosed without prior written permission from Money Controls

## b) 'Emergency stop' command issued during payout sequence

Counter	Initial value	Pay 3 from 10 then 'Emergency stop'	Cycle power off then on
'Emergency stop' return value	0	→7←	0
Last payout : coins paid	0	3	3
Last payout : coins unpaid	0	7	ZERO
Hopper dispense count	0	3	3
Hopper life dispense count	N	N + 3	N + 3

**Coins remaining = 7**

## c) 'Emergency stop' command issued during payout sequence AND a coin is seen after the hopper replies with unpaid coins.

Counter	Initial value	Pay 3 from 10 then 'Emergency stop' + late coin exit	Cycle power off then on
'Emergency stop' return value	0	7 →6← on retry	0
Last payout : coins paid	0	4	4
Last payout : coins unpaid	0	→6←	<b>ZERO</b>
Hopper dispense count	0	4	4
Hopper life dispense count	N	N + 3	N + 4

**Coins remaining = 6**

In this more complicated example, the hopper dispense count and the hopper life dispense count end up with the correct values even though a coin was seen on the exit optos after the motor stopped. For the host machine to find the correct value of unpaid coins it would need to re-send the 'Emergency stop' command or use the 'Request hopper status' command **before** power was lost - otherwise it would think there were 7 unpaid coins rather than 6.

Therefore if you need to know the number of remaining coins during a power fail and wish to use the 'Emergency stop' command, please ensure that you have enough time to send this command and a 'Request hopper status' before power is lost. This gives the best possible accuracy. The host machine needs at least **100ms** of notice before the power supply dips below Vtrip ( see Appendix B ).

---

CONFIDENTIAL

Not to be disclosed without prior written permission from Money Controls

## 12. What happens...?

### 12.1 What happens after Power Up ?

The following is a guide to what happens when power is lost and re-applied.

**Device Address**

Defaults to the connector address

**PIN Number**

Retained but needs to be re-entered

**Motor Variables**

[ current limit ] = default value

[ motor stop delay ] = default value

[ payout timeout ] = default value

[ maximum current measured ] = ZERO

See Appendix A for default values.

**Flags**

Refer to the Flag Action Table within the 'Test hopper' command description.

Note that the 'Power-up' flag is set to indicate the power supply really was lost and the hopper defaults to multi-coin payout mode. The hopper also starts inhibited and needs to be enabled prior to coin dispensing.

Counter checksum flags are updated.

**Counters**

Hopper dispense count = last value

Hopper life dispense count = last value

**Request hopper status**

[ event counter ] = ZERO

[ payout coins remaining ] = ZERO

[ last payout : coins paid ] = last value

[ last payout : coins unpaid ] = ZERO or last value if power lost during payout

**Request comms status variables**

[ rx timeouts ] = ZERO

[ rx bytes ignored ] = ZERO

[ rx bad checksums ] = ZERO

Continued...

---

CONFIDENTIAL

Not to be disclosed without prior written permission from Money Controls

Page 22 of 53

## 12.2 What happens after Software Reset ?

The following is a guide to what happens after a software reset. A software reset means sending the 'Reset device' command to the hopper.

### **Device Address**

Defaults to the connector address

### **PIN Number**

Retained but needs to be re-entered

### **Motor Variables**

[ current limit ] = default value

[ motor stop delay ] = default value

[ payout timeout ] = default value

[ maximum current measured ] = ZERO

See Appendix A for default values.

### **Flags**

Refer to the Flag Action Table within the 'Test hopper' command description.

Note that the 'Power-up' flag is cleared. The hopper also starts inhibited and needs to be enabled prior to coin dispensing.

Counter checksum flags are updated.

### **Counters**

Hopper dispense count = last value

Hopper life dispense count = last value

### **Request hopper status**

[ event counter ] = ZERO

[ payout coins remaining ] = ZERO

[ last payout : coins paid ] = last value

[ last payout : coins unpaid ] = last value

### **Request comms status variables**

[ rx timeouts ] = ZERO

[ rx bytes ignored ] = ZERO

[ rx bad checksums ] = ZERO

## 13. Simple Coin Payout

The following shows the minimum command set needed to pay out some coins after receiving a 'factory-fresh' hopper. This will be helpful when writing new software drivers or for testing.

We will assume that the hopper is on address 3 and has just powered-up.

Send the following commands...

- Enable hopper
- Request cipher key
- Dispense hopper coins
- Request hopper status

In detail...

Message packets are shown in full ( not just the data part ). The host address is assumed to be 1 and [ byte values ] are in decimal.

### Enable hopper

```
TX:  [ 3 ][ 1 ][ 1 ][ 164 ][ 165 ][ 178 ]
RX:  [ 1 ][ 0 ][ 3 ][ 0 ][ 252 ] = ACK
```

### Request cipher key

```
TX:  [ 3 ][ 0 ][ 1 ][ 160 ][ 92 ]
RX:  [ 1 ][ 8 ][ 3 ][ 0 ][ key 1 ][ key 2 ][ key 3 ][ key 4 ][ key 5 ]
      [ key 6 ][ key 7 ][ key 8 ][ checksum ]
```

The data bytes returned by this command are used in the encryption algorithm. For security reasons details of the encryption algorithm are not given in this document.

### Dispense hopper coins

```
TX:  [ 3 ][ 1 ][ 1 ][ 167 ][ sec 1 ][ sec 2 ][ sec 3 ][ sec 4 ][ sec 5 ]
      [ sec 6 ][ sec 7 ][ sec 8 ][ N coins ][ checksum ]
RX:  [ 1 ][ 1 ][ 3 ][ 0 ][ event counter ][ checksum ]
```

Between 1 and 255 coins can be dispensed with this command.

### Request hopper status

```
TX:  [ 3 ][ 0 ][ 1 ][ 166 ][ 86 ]
RX:  [ 1 ][ 4 ][ 3 ][ 0 ][ event counter ][ payout coins remaining ]
      [ last payout : coins paid ][ last payout : coins unpaid ]
      [ checksum ]
```

This command should be repeated until [ payout coins remaining ] = 0. Another cipher key can then be requested and more coins dispensed.

## 14. Full Initialisation & Payout Sequence

This is an example of a full initialisation and payout sequence on SUH...

Notation : `cctalk command's` are shown highlighted.

Optional... **Address Resolution**

If { network indeterminate } then

`Address poll` ⇒ resolve addresses with BROADCAST address

While { Address clash on any address } then

`Address random` ⇒ scramble addresses with BROADCAST address

`Address poll` ⇒ resolve addresses with BROADCAST address

`Request equipment category id` ⇒ identify each device on bus

`Address change` ⇒ assign new addresses if required

*In other words, if we do not know where the serial hoppers are on the bus then we need to locate them. If any of the device addresses clash then we need to scramble them and look again. However, since the wiring harness for the hopper should initialise the device addresses in a non-ambiguous manner, this address resolution software can be avoided.*

### Initialisation

`Simple poll` ⇒ returns ACK to confirm device is attached, powered-up and 9600 baud comms is working fine

`Request equipment category id` ⇒ returns 'Payout'. Otherwise you will probably be trying to dispense a coin from an acceptor !

`Request variable set` ⇒ connector address ( physical position in machine )

`Request serial number` ⇒ store for reference

Optional... **Product Data**

`Request manufacturer id` ⇒ e.g. 'Money Controls'

`Request product code` ⇒ e.g. 'SUH'

`Request software revision` ⇒ e.g. 'SUH1-Vx.y'

`Request comms revision` ⇒ cctalk comms level

`Request hopper coin` ⇒ coin name if stored

`Request build code` ⇒ level sensor details

### PIN Number Unlocking

`Test hopper` ⇒ check to see if PIN number mechanism is enabled

If { PIN enabled } then

`Enter PIN number`

else

`Enter new PIN number` ⇒ randomise and log against serial number for future reference

Optional... `Write data block` ⇒ log host id in user data memory

*The PIN number mechanism should only be enabled if the host machine has some way of remembering it ! The easiest method is to make all the PIN numbers the same but that is not very secure. It is much better to randomise them but in that case there will be problems if hoppers are swapped between machines. You may wish to implement a central database of PIN numbers versus serial numbers or perhaps make use of the user data section of the hopper memory to store an encrypted PIN number.*

Continued...

---

CONFIDENTIAL

Not to be disclosed without prior written permission from Money Controls

Page 25 of 53

**Product Configuration**

**Modify variable set** ⇒ set current limit  
set motor stop delay  
set payout timeout  
set single coin payout mode

*Default values can be used if so desired in which case this command can be skipped. Single coin payout mode is more secure though because once in this mode an external bus attack can at best only pay out a single coin at a time rather than emptying the contents of the hopper. This assumes all the other security mechanisms have been defeated. However, single coin payout mode is much slower.*

**Remove Payout Inhibit**

**Enable hopper** ⇒ prepare for payout by allowing the dispense command

**Check for Residual Payout from a Power Fail**

**Test hopper** ⇒ check for NV Memory write fail or checksum error

If { counter error } then

**Write data block** ⇒ if good host copy exists then correct counter

else

**Request hopper status** ⇒ check to see if there are residual coins after last payout. If so then take the decision to pay out the balance.

Optional... **Request hopper dispense count** ⇒ check with last known host copy to see if an illegal payout has been made

*Errors in the hopper memory should not occur under normal operating conditions. If one of the counters become corrupted however it would be possible to restore their contents if the host machine has a backup copy.*

**Dispense Coin**

**Test hopper** ⇒ check error flags are clear

If { error flags } then

< take appropriate action on possible fraud attempt >

**Reset device** ⇒ clear error flags

**Enter PIN number** ⇒ if enabled

**Modify variable set** ⇒ set current limit, stop delay, timeout, single coin mode

**Enable hopper** ⇒ re-enable hopper after reset

**Pump RNG** ⇒ send some random numbers to the hopper

**Request cipher key** ⇒ ready for encryption algorithm

**Dispense hopper coins** ⇒ pay out one or more coins

If { Dispense NAK } then

Something went wrong - find out why ?

Continued...

---

CONFIDENTIAL

Not to be disclosed without prior written permission from Money Controls

Page 26 of 53

**Dispense Verification**

Request hopper status ⇒ check event counter

If { event counter not incremented } then

    Retry Dispense hopper coins

While { payout coins remaining > 0 }

    Request hopper status

Test hopper ⇒ check error flags are clear

If { error flags set } then

    Resolve from the following error conditions...

    <Coin jam> if max. current exceeded

    <Hopper empty> if payout timeout

    <Opto fraud attempt> if any opto error flag

**Optional... Level Auditing**

Request hopper dispense count ⇒ store host copy for subsequent verification

Request payout high / low status ⇒ is the hopper nearly empty ?

**Early Notification of Power Fail**

Emergency stop

Request hopper status ⇒ store unpaid coins for next power-up initialisation

Wait for power to disappear

## 15. Command List

34 commands are supported...

*Table 3: Command List.*

<a href="#">Header 254</a>	Simple poll
<a href="#">Header 253</a>	Address poll
<a href="#">Header 252</a>	Address clash
<a href="#">Header 251</a>	Address change
<a href="#">Header 250</a>	Address random
<a href="#">Header 247</a>	Request variable set
<a href="#">Header 246</a>	Request manufacturer id
<a href="#">Header 245</a>	Request equipment category id
<a href="#">Header 244</a>	Request product code
<a href="#">Header 242</a>	Request serial number
<a href="#">Header 241</a>	Request software revision
<a href="#">Header 236</a>	Read opto states
<a href="#">Header 219</a>	Enter new PIN number
<a href="#">Header 218</a>	Enter PIN number
<a href="#">Header 217</a>	Request payout high / low status
<a href="#">Header 216</a>	Request data storage availability
<a href="#">Header 215</a>	Read data block
<a href="#">Header 214</a>	Write data block
<a href="#">Header 192</a>	Request build code
<a href="#">Header 172</a>	Emergency stop
<a href="#">Header 171</a>	Request hopper coin
<a href="#">Header 169</a>	Request address mode
<a href="#">Header 168</a>	Request hopper dispense count
<a href="#">Header 167</a>	Dispense hopper coins
<a href="#">Header 166</a>	Request hopper status
<a href="#">Header 165</a>	Modify variable set
<a href="#">Header 164</a>	Enable hopper
<a href="#">Header 163</a>	Test hopper
<a href="#">Header 161</a>	Pump RNG
<a href="#">Header 160</a>	Request cipher key
<a href="#">Header 004</a>	Request comms revision
<a href="#">Header 003</a>	Clear comms status variables
<a href="#">Header 002</a>	Request comms status variables
<a href="#">Header 001</a>	Reset device

---

CONFIDENTIAL

Not to be disclosed without prior written permission from Money Controls

Page 28 of 53

## 15.1 Commands in Detail

All byte values shown in [ decimal ] unless otherwise stated.

### Header 254: Simple poll

Transmitted data : <none>  
Received data : ACK

This is a good command to use to confirm that a device is plugged into the expected address, powered-up and operating correctly. A total of 5 bytes are sent to the hopper which then replies with 5 bytes.

### Header 253: Address poll

Transmitted data : <none>  
Received message : {variable delay} <slave address byte>

Only a single byte is returned by the hopper rather than a full cctalk message packet.

See the ccTalk<sup>®</sup> generic specification for more details.

### Header 252: Address clash

Transmitted data : <none>  
Received message : {variable delay} <slave address byte>

Only a single byte is returned by the hopper rather than a full cctalk message packet.

See the generic specification for more details.

### Header 251: Address change

Transmitted data : [ address ]  
Received data : ACK

The address specified overrides that determined by the connector wiring loom. The new value is lost at power-down or reset.

### Header 250: Address random

Transmitted data : <none>  
Received data : ACK

The address is randomly set to a value between 3 and 255. The broadcast address 0, the default bus master address 1, and the default coin acceptor address 2, are automatically avoided for your convenience. The new value is lost at power-down or reset.

**Header 247: Request variable set**

Transmitted data : <none>  
Received data : [ current limit ] [ motor stop delay ] [ payout timeout ]  
[ maximum current measured ] [ supply voltage ]  
[ connector address ] [ current limit ]

This is the current threshold at which the motor reverses in order to clear jams.

Refer to CURLMT in Appendix A for details of scaling and its default value.

**[ motor stop delay ]**

This is the time the motor is allowed to run on for after detecting the last coin in a payout sequence and should be sufficient for the coin to exit cleanly.

Refer to STOPDLY in Appendix A for details of scaling and its default value.

**[ payout timeout ]**

This is the total amount of time allowed for each coin to be paid out, allowing for some reversing in the event of a jam. After this time, the motor is stopped.

Refer to PAYTIM in Appendix A for details of scaling and its default value.

**[ maximum current measured ]**

Measured with the same units as [ current limit ]. The current is sampled and averaged as the motor is running and should be used as an approximate guide only.

This measurement can be cleared to zero with the 'Reset device' command.

**[ supply voltage ]**

The hopper can measure its own power supply voltage and report it back to the host machine. The supply voltage is sampled continuously when not paying out coins.

Refer to SUPVOLTS in Appendix A for details of scaling.

**[ connector address ]**

Range 0 to 7.

This is the number specified by the address select pins on the connector. The device address on the cctalk bus is this value plus 3 if it hasn't been changed subsequently on serial.

Note that this value is recorded at power-up or reset only.

*Software Design Note* : Future products may see some additional information returned by this command. To ensure backwards compatibility, the existing data packet will be retained ( in both order and type ) and any additional information tagged to the end. If a feature is not supported, the relevant byte will return zero.

**Header 246: Request manufacturer id**

Transmitted data : <none>  
Received data : "Money Controls"

**Header 245: Request equipment category id**

Transmitted data : <none>  
Received data : "Payout"

**Header 244: Request product code**

Transmitted data : <none>  
Received data : "SUH1"

SUH = Serial Universal Hopper Mk1.

**Header 242: Request serial number**

Transmitted data : <none>  
Received data : [ serial 1 - LSB ] [ serial 2 ] [ serial 3 - MSB ]

This is a 24-bit binary serial number.

Prototype units return...

[ 78 ] [ 97 ] [ 188 ] in decimal

[ 4E ] [ 61 ] [ BC ] in hex

= 12,345,678

If you work it out as 5,136,828 you have the bytes in reverse order!

Production units will be supplied with a unique, incremental serial number. Serial numbers cannot be changed by any easy means.

**Header 241: Request software revision**

Transmitted data : <none>  
Received data : "SUH1-Vx.y"

x, y = 0, 1, 2... depending on the revision level of the software.

**Header 236: Read opto states**

Transmitted data : <none>  
Received data : [ payout opto ]

[ payout opto ]

Bit mask :

B0 - payout opto A ( 0 = path clear, 1 = path blocked )

B1 - payout opto B

B2 - payout opto C

B3 to B6 - not used, 0 returned

B7 - payout opto A + B + C

The payout opto whose status is returned on bit 7 is actually comprised of 3 separate opto paths - A, B and C. If a coin is seen at any of these optos then bit 7 is set.

The optos are continuously sampled in the background and the current state is reported by this command.

Note that this command is designed for test purposes only ( checking coin visibility on the opto-electronics ) and not for counting coins during a payout sequence ! Counting coins during payout is handled automatically by the software and is performed a lot faster than polling serially.

**Header 219: Enter new PIN number**

Transmitted data : [ PIN1 ][ PIN2 ][ PIN3 ][ PIN4 ]  
Received data : ACK

A factory-fresh hopper has the PIN number mechanism disabled.

A manufacturer can subsequently program the PIN number to any chosen value using this command and after that the number cannot be changed, even if the existing PIN number has been entered correctly. It is a 'once-only' lockout mechanism - turning the power off and on does not clear the PIN number.

A PIN number of [ 0 ][ 0 ][ 0 ][ 0 ] is legal and would have to be entered.

The 'Dispense hopper coins' command is the only one which is 'blocked' by the PIN number mechanism - all other commands operate as normal.

Entering a new PIN number after one has already been programmed will still result in the return of an ACK even though the PIN number remains unchanged.

The 'Test hopper' command can be used to see if a PIN number has been programmed - refer to bit 7 of 'hopper status register 2'.

**Header 218: Enter PIN number**

Transmitted data : [ PIN1 ][ PIN2 ][ PIN3 ][ PIN4 ]  
Received data : ACK

If the PIN number mechanism is enabled then the 'Dispense hopper coins' command will not work unless the correct PIN number has been entered. The current PIN number is lost after a...

- power-down
- hardware reset
- software reset
- emergency stop with the motor running

Incorrect PIN numbers are always ACK'ed as if they had worked.

**Header 217: Request payout high / low status**

Transmitted data : <none>  
Received data : [ level status ]

This command returns the status of the level sensor.

**[ level status ]**

Bit mask :

Bit 0 - Low level sensor status ( 1 = lower than low level trigger )

Bit 1 - High level sensor status ( 1 = higher than or equal to high level trigger )

Bit 2 - not used

Bit 3 - not used

Bit 4 - Low level sensor support ( 1 = feature supported and fitted )

Bit 5 - High level sensor support ( 1 = feature supported and fitted )

Bit 6 - not used

Bit 7 - not used

For the operator...

Bit 0 is set if the hopper is NEARLY EMPTY.

Bit 1 is set if the hopper is NEARLY FULL.

The normal operating condition of the hopper is bits 0 & 1 clear.

If the raw level sensor inputs are reading NEARLY EMPTY as well as NEARLY FULL then this is an illegal condition (it can only be one or the other) and bits 0 & 1 are both left clear.

The level sensor inputs are debounced with a time Tlevdeb in Appendix B to remove the effects of shifting coins.

**Header 216: Request data storage availability**

Transmitted data : <none>  
 Received data : [ memory type ] [ read blocks ] [ read bytes per block ]  
 [ write blocks ] [ write bytes per block ]

[ memory type ] = 2, permanent ( limited use )  
 [ read blocks ] = 4  
 [ read bytes per block ] = 8  
 [ write blocks ] = 3  
 [ write bytes per block ] = 8

In other words, 32 bytes of NV Memory are available for reading, 24 bytes for writing, accessed 8 bytes at a time.

Refer to Appendix D for details of the memory map.

**Header 215: Read data block**

Transmitted data : [ block number ]  
 Received data : [ data 1 ] [ data 2 ]... [ data 8 ]

[ block number ]  
 0 to 3

Provides read access to the NV Memory.

Refer to Appendix D for details of the memory map.

**Header 214: Write data block**

Transmitted data : [ block number ] [ data 1 ] [ data 2 ]... [ data 8 ]  
 Received data : ACK

[ block number ]  
 0 to 2

Provides write access to the NV Memory.

Refer to Appendix D for details of the memory map.

**Header 192: Request build code**

Transmitted data : <none>  
 Received data : 8 x ASCII chars

The build code is determined automatically by the hopper during initialisation. It is assumed any build options do not change while power remains on the unit, otherwise a software reset needs to be issued.

`Lev HiLo' for high and low level sensor fitted  
 `Lev Hi ' for high level sensor only fitted  
 `Lev Lo' for low level sensor only fitted  
 `Standard' for standard model, no extras ( as per SCH1 )

**Header 172: Emergency stop**

Transmitted data : <none>  
Received data : [ payout coins remaining ]

If this command is sent during a payout then the motor is stopped immediately as a precursor to power being lost. The returned byte counter should indicate the remaining coins to be paid out.

The effect on the 'Request hopper status' command is as follows...

[ payout coins remaining ] ⇒ Cleared to ZERO  
[ last payout : coins paid ] ⇒ Coins paid prior to stopping  
[ last payout : coins unpaid ] ⇒ Coins unpaid prior to stopping

The 'Emergency stop' command produces a similar action to a software reset when the motor is running. This means that the hopper will need to be re-initialised ( PIN number, enable etc. ) prior to dispensing further coins.

When the motor is not running, this command returns the [ payout coins remaining ] value without performing a reset.

**Header 171: Request hopper coin**

Transmitted data : <none>  
Received data : 6 x ASCII chars

This command returns an ASCII string consisting of 6 characters. These are stored in the NV Memory.

Coin names are returned as [ C ] [ C ] [ V ] [ V ] [ V ] [ I ] - refer to the cctalk generic specification for an explanation of the format.

The 'unprogrammed' state of the coin name may typically be 6 x ASCII code 45 ( ----- ) or 6 x ASCII code 0.

*Note : There is no facility currently in production software to program in the name of the coin that will be dispensed, particularly as this is a 'Universal' hopper and may be used to dispense a variety of coins. The machine manufacturers will be at liberty to program in their own coin labels using the 'Write data block' command.*

**Header 169: Request address mode**

Transmitted data : <none>  
Received data : [ address mode ]

The address selection method is determined by the product and in this case the value **4A hex** is always returned. The use of this command is 'informational only' but will be useful in future when a number of serial hopper products exist on the market which have different address selection mechanisms.

[ address mode ]

Bit mask :

B0 - Address is stored in ROM

B1 - Address is stored in RAM

B2 - Address is stored in EEPROM or battery-backed RAM

B3 - Address selection via interface connector

B4 - Address selection via PCB links

B5 - Address selection via switch

B6 - Address may be changed with serial commands ( volatile )

B7 - Address may be changed with serial commands ( non-volatile )

4A hex =       Address stored in RAM  
                  Address selection via interface connector  
                  Address may be changed with serial commands ( volatile )

The address of the hopper defaults to that in the connector wiring after a power-up or software reset.

**Header 168: Request hopper dispense count**

Transmitted data : <none>  
Received data : [ no. of coins 1 - LSB ] [ no. of coins 2 ] [ no. of coins 3 - MSB ]

Range 0 to 16,777,215.

The dispense counter records the number of coins dispensed since the counter was last cleared.

The counter returned is the 'reset-able' one, not the life counter which is made available via the 'Read data block' command. See the memory map description in Appendix D for more details and the mechanism for clearing the counter.



**Header 166: Request hopper status**

Transmitted data : <none>  
 Received data : [ event counter ] [ payout coins remaining ]  
 [ last payout : coins paid ] [ last payout : coins unpaid ]

**[ event counter ]**

Every valid 'Dispense hopper coins' command increments the event counter. Valid means there was no comms error in the command packet.

The event counter only has the value 0 at power-up or reset - if its value is 255 and another dispense command is received then the event counter changes to 1. Then 2, 3, 4 etc.

The event counter is added for security reasons - if the reply to a 'Dispense hopper coins' command is corrupted or missing due to noise then the event counter should be checked prior to re-transmitting the command to prevent over payout of coins. Correctly written host software should always check the event counter before re-sending a dispense command.

**[ payout coins remaining ]**

After a 'Dispense hopper coins' command this counter is primed with the number of coins to pay out. It then **decrements** with each coin dispensed until it reaches zero.

**[ last payout : coins paid ]**

The number of coins paid out in the last 'Dispense hopper coins' command. This counter **increments** as coins are being paid out.

**[ last payout : coins unpaid ]**

The number of coins which failed to be paid out in the last 'Dispense hopper coins' command. This counter is **cleared** during a payout.

As soon as a dispense hopper coins command is received, the status bytes are updated as follows...

[ payout coins remaining ]   ⇒ 'N coins' / **decrements** as each coin is paid out  
 [ last payout : coins paid ]   ⇒ Cleared to ZERO / **increments** as each coin is paid out  
 [ last payout : coins unpaid ]   ⇒ Cleared to ZERO

When payout is completed ( success or abort ) then the status bytes become...

[ payout coins remaining ]   ⇒ Cleared to ZERO  
 [ last payout : coins paid ]   ⇒ Correct value for last operation  
 [ last payout : coins unpaid ]   ⇒ Correct value for last operation

**Host software should always wait for [ payout coins remaining ] to reach zero before deciding what to do next.**

**Request hopper status : Coding Recommendations**

Using life test results, Money Controls can now make the following coding recommendations...

Polling the hopper status after a 'Dispense hopper coins' command is best done every **200ms**. It is essential that a retry mechanism is put in place such that if there is no reply to the 'Request hopper status' command after **50ms** then it is sent again. The number of **sequential** retries allowed before a hardware fault is suspected should be set at around **10**. The reason for the heavy retry mechanism is the electrical noise generated by the motor. If suitable measures are taken in software then the serial communication link should be 100% reliable and this has been confirmed by tests at Money Controls.

**Header 165: Modify variable set**

Transmitted data : [ current limit ] [ motor stop delay ]  
[ payout timeout ] [ single coin mode ]  
Received data : ACK

Refer to 'Request variable set' for more details - the format of data is the same.

[ single coin mode ]

0 - set multi-coin payout mode ( default )

1 - set single coin payout mode

( any other value is treated as multi-coin payout mode )

**For security reasons, once a hopper is set to single coin payout mode it cannot be changed back to multi-coin payout mode with this command. A power-down or hardware / software reset is required.**

This command allows some of the motor control variables to be modified but does not necessarily have to be sent before using the hopper. The default values listed in Appendix A are normally optimal.

Variable set changes are volatile. Any custom values are lost at power-down or reset.

*Software Design Note: Future products may see some additional information sent by this command. To ensure backwards compatibility, the existing data packet will be retained ( in both order and type ) and any additional information tagged to the end. If a feature is not supported, the relevant byte will be ignored.*

**Header 164: Enable hopper**

Transmitted data : [ enable code ]  
Received data : ACK

[ enable code ]

165 - enable hopper payout

not 165 - disable hopper payout

The hopper must be enabled before coins can be paid out. Only the decimal value 165 ( A5 hex, 10100101 binary ) enables it, all other values disable it.

If a hopper is disabled prior to a 'Dispense hopper coins' command, a NAK is returned.

**A 'Reset device' command or a power-down cycle will cause the hopper to be disabled by default.**

This command is retained for compatibility with SCH1 rather than its negligible effect on security.

**Header 163: Test hopper**

Transmitted data : <none>  
Received data : [ hopper status register ]

This command reports back various operating and error flags from the hopper and is the equivalent of the 'Perform self-check' command in coin acceptors.

**[ hopper status register 1 ]**

Bit mask :

B0 - Absolute maximum current exceeded	1 = exceeded
B1 - Payout timeout occurred	1 = occurred
B2 - Motor reversed during last payout to clear a jam	1 = reversed
B3 - Opto fraud attempt, path blocked during idle	1 = fraud
B4 - Opto fraud attempt, short-circuit during idle	1 = fraud
B5 - Opto blocked permanently during payout	1 = blocked
B6 - Power-up detected	1 = power-up
B7 - Payout disabled	1 = disabled

The 'Payout timeout occurred' flag is cleared prior to each dispense operation.

Once it has been set, the 'Motor reversed during last payout to clear a jam' flag stays latched through subsequent dispense operations but may be cleared with a software reset.

**[ hopper status register 2 ]**

Bit mask :

B0 - Opto fraud attempt, short-circuit during payout	1 = fraud
B1 - Single coin payout mode	1 = single
B2 - Checksum A error	1 = error
B3 - Checksum B error	1 = error
B4 - Checksum C error	1 = error
B5 - Checksum D error	1 = error
B6 - Power fail during NV Memory write	1 = fail
B7 - PIN number mechanism	1 = enabled

'Opto fraud attempt, short-circuit during payout' occurs if light is shone at the hopper exit optos during a dispense operation.

Refer to Appendix D for details of the checksum types.

Table 4: Flag Action Table:

Short Label	Dispense coins requirement ?	Action on Power-Up or Hardware Reset	Action on Software Reset
Max. Curr.	Yes	Cleared	Cleared
Timeout	-	Cleared	Cleared
Reverse	-	Cleared	Cleared
Idle block	Yes	Cleared	Cleared
Idle s/c	Yes	Cleared	Cleared
Block	Yes	Cleared	Cleared
Power-up	-	Set on PU only	Cleared
Disabled	Yes	Set	Set
Pay s/c	Yes	Cleared	Cleared
Single	-	Cleared	Cleared
Check A	-	Calculated	Calculated
Check B	-	Calculated	Calculated
Check C	-	Calculated	Calculated
Check D	-	Calculated	Calculated
NV Fail	-	'NV Memory'	'NV Memory'
PIN	-	'NV Memory'	'NV Memory'

**Header 161: Pump RNG**

Transmitted data : [ random 1 ] [ random 2 ] [ random 3 ] [ random 4 ]  
 [ random 5 ] [ random 6 ] [ random 7 ] [ random 8 ]  
 Received data : ACK

This command pumps the random number generator of the hopper with extra random variables to make prediction of the next random number in the sequence a lot harder. Its use is optional but recommended where security is paramount.

**Header 160: Request cipher key**

Transmitted data : <none>  
 Received data : [ key 1 ] [ key 2 ] [ key 3 ] [ key 4 ]  
 [ key 5 ] [ key 6 ] [ key 7 ] [ key 8 ]

This command requests the encryption key required for coin payout. It may be requested repeatedly in the event of a comms error since it only changes after a...

- 'Dispense hopper coins' command
- 'Pump RNG' command
- Power-down or any type of reset

**Header 004: Request comms revision**

Transmitted data : <none>  
 Received data : [ cctalk level ] [ major revision ] [ minor revision ]

[ cctalk level ] = 1  
 [ major revision ] = 3  
 [ minor revision ] = 2

In other words, the first issue level of cctalk specification 3.2

---

CONFIDENTIAL

**Header 003: Clear comms status variables**

Transmitted data : <none>  
Received data : ACK

Clears the counters returned by the 'Request comms status variables' command.

**Header 002: Request comms status variables**

Transmitted data : <none>  
Received data : [ rx timeouts ] [ rx bytes ignored ] [ rx bad checksums ]

**[ rx timeouts ]**

Number of receive message timeouts recorded by the processor.

There is an inter-byte timeout value of Trxout - see Appendix B. The cctalk protocol has a variable length packet structure but data timeouts can be detected and counted.

**[ rx bytes ignored ]**

Number of receive bytes ignored by the processor ( due to receive buffer overflow ).

SUH has a receive buffer length of 15 bytes for the data part of the packet - the header and checksum are stored elsewhere. Packets with more than 15 bytes of data increase the ignored counter by the total number of data bytes. So sending a message with 20 data bytes would increase the ignored bytes by 20. Likewise a message with 15 or less would not do anything to the counter, a message with 16 by 16 and a message with 252 by 252.

**[ rx bad checksums ]**

Number of messages received by the processor with bad checksums.

*All these counters are cumulative and wrap around to 0 after 255.*

When testing a new software driver, it is worth checking these counters after a series of message transactions to confirm all is well.

**Header 001: Reset device**

Transmitted data : <none>  
Received data : ACK

This is the command required for a 'software reset'.

An ACK is returned **prior** to resetting.

Host software should allow a delay after the ACK before sending the next command to allow the hopper initialisation code to complete - see TSinit in Appendix B.

After a 'Reset device' command, various status flags are cleared ( see the 'Test hopper' command ).

Any motor parameters sent with a 'Modify variable set' command will return to their default values. Default values are given in Appendix A.

## 16. Power Distribution on a Multi-Drop Bus

The multi-drop bus for Serial Universal Hoppers consists of a power, ground and serial data line. When more than one hopper is attached to the bus, all power is transferred along a single cable and significant ground potential rises can occur.

The following recommendations are made...

- Only operate one serial hopper at a time. Never initiate a second payout sequence when one is already in progress.
- Consider the use of signal conditioning on the serial data line receiver. Perhaps a high-frequency filter and voltage comparator input with a mid-rail ( 2.5V ) threshold.
- Consider running separate power cables to the hoppers to alleviate the ground potential problem.
- If communication errors still occur, consider changing the topology of the multi-drop bus network. A star network will distribute power more evenly than a ring, tree or daisy-chain network.

## 17. Electrical Noise - Physical Measures

The cctalk protocol is not designed for long distance transfer but for local hook-up of various peripherals within a machine cabinet. Typical cable lengths are likely to be of the order of a few metres.

Various measures can be taken to minimise the effects of radiated and conducted noise on the cctalk bus.

- Use a good quality regulated power supply with mains filtering. The power rating should be sufficient to handle a Serial Universal Hopper at maximum surge current.
- Do not run the multi-drop bus cables directly next to noisy electrical components if at all possible. These are typically motors, relays, VDU's, fluorescent strip lights etc. If problems are experienced consider the use of screened cable.
- Keep cable runs as short as possible.
- Make sure the cctalk data line has an appropriate load resistor at the host end ( typically 1K to 10K pull-up to +5V ).
- Do not place too many peripherals on the bus - consider the loading effects of each cctalk interface circuit. The maximum number allowed will depend on the host transceiver circuit.

## 18. Electrical Noise - Software Measures

There is a big difference in security and reliability terms between a good software implementation of cctalk and that of a poor one.

The following design points should be noted carefully...

Check each cctalk reply packet for errors.

- Was there a low level byte framing error ?
- Were there the correct number of data bytes in the message ?
- Was the return destination address correct ?
- Was the checksum correct ?
- Was the peripheral source address the one expected ?
- Was the return header zero ?

If a reply is returned with an error then the cctalk command can be re-transmitted as many times as deemed appropriate - this is a key feature of cctalk.

Note that the [ rx bad checksums ] byte returned by the 'Request comms status variables' command is useful for monitoring noise.

## 19. Electrical Specification

### 24 volt motor version

*Table 5: Electrical Specification*

Electrical Specification	Value
Supply Voltage	+19 to 26V
Typical Operating Current/No Load	300mA typical
Typical Operating Current/Max Load	700mA typical
Surge Current/Start Up and Reverse	2.5A peak

### 19.1 Coin Payout:

*Table 6: Coin Payout Rate*

Mode	Rate
Multi coin payout	3 - 5 coins per second approx
Single coin payout	1.5 coins per second approx

The much slower single-coin payout mode is due mainly to the overheads of encryption.

### 19.2 Environmental:

*Table 7: Environmental Ranges*

Operating Temperature	0 to 60 <sup>0</sup> C
Storage Temperature	-20 to 70 <sup>0</sup> C
Operating Humidity	10 to 75% RH
Storage Humidity	10 to 95% RH non condensing

## 20. Maintenance Schedule

*Table 8: Maintenance Schedule*

Maintenance Schedule	
Every 100,000 coins	Clean the light guide using a mild detergent on a damp cloth. No spray solvents should be used.
Expected product lifetime:	3 million coins with routine maintenance

## 21. Fault Finding and Repair

*Table 9: Fault Finding and repair.*

Problem:	Check:	Cure:
Coins fail to unjam:	Ensure coin exit is clear.	Remove blockage from coin exit.
	Ensure correct coins in hopper.	Fill hopper with correct coins.
	Ensure no badly bent coins in hopper.	Remove bent coin/s.
Motor fails to run:	Supply fuse.	Replace fuse.
	Protection device tripped.	Wait 30 seconds with supply OFF.
	Hopper has detected an opto fault.	Check EEPROM flags.
Over payout of coins:	Check opto area/coin exit area for dirt.	Clean opto/coin exit area.
Under Payout Of Coins:	Check opto area/coin exit area for dirt.	Clean opto/coin exit area.
	Ensure hopper contains sufficient coins.	Refill hopper.

## 22. Appendix A

### 22.1 Conversion Equations & Default Values

Table 10: Conversion Equations & Default Values:.

Label	Scaling & Units	Default Byte Value	Default Physical Value
CURLMT	$N / 17.1$ Amps	20	1.2A
STOPDLY	$N$ ms	0	0ms
PAYTIM	$N * 0.333$ s	30	10s
SUPVOLTS	$0.2 + N * 0.127$ Volts	188	24V

### 22.2 Limits

The value of CURLMT cannot be set lower than 6 ( which corresponds to 0.35A ) otherwise the unit will not operate properly. If a value smaller than 6 is specified, the original value is retained.

The value of STOPDLY cannot be set greater than 50 ( 50ms ) for security reasons. If a value larger than 50 is specified, the value is clamped at 50.

### 22.3 Software Reset

A software reset will force the motor parameters to return to their default values, regardless of their current state.

## 23. Appendix B

### 23.1 Timing Parameters

*Table 11: Timing Parameters:*

Nominal values are shown.

Label	Description	Value	Units
Xtal	PIC Resonator	4.0	MHz
Brate	Serial communication baud rate	9600	baud
Trxout	Receive data timeout	25	ms
Vtrip	Power-fail trip threshold ( +24V motor )	16	V
TPinit	Power-up initialisation time	600	ms
TSinit	Software reset initialisation time	< 40	ms
TMreverse	Motor reversing time	150	ms
TEESave	EEPROM data save time	17	ms
Ifuse	Absolute maximum trip current	5	A
Tlevdeb	Level sensor debounce time	2	s
	Comms reply delay : Simple poll	< 2	ms
	Comms reply delay : Enter PIN number ( correct )	< 2	ms
	Comms reply delay : Enter PIN number ( wrong )	235	ms
	Comms reply delay : Write data block	8	ms
	Comms reply delay : Dispense hopper coins	< 4	ms
	Comms reply delay : Request hopper status	< 2	ms
	Comms reply delay : Pump RNG	< 2	ms
	Comms reply delay : Request cipher key	< 2	ms

### 23.2 Opto Security Timing

When idle, the hopper software tests the optos on a pseudo-random basis to make a deliberate fraud attempt much harder. The sampling period varies between 15 and 255 milliseconds. When paying out coins, the sampling period changes to between 64 and 127 milliseconds.

### 23.3 Hopper Initialisation

No serial communication is possible during the 'TPinit', 'TRinit' and 'TSinit' time.

## 24. Appendix C

### 24.1 ccTalk<sup>®</sup> Interface Circuit

This is the cctalk electronic interface circuit on SUH.

There are many options for the host interface circuit but we recommend an open-collector drive.

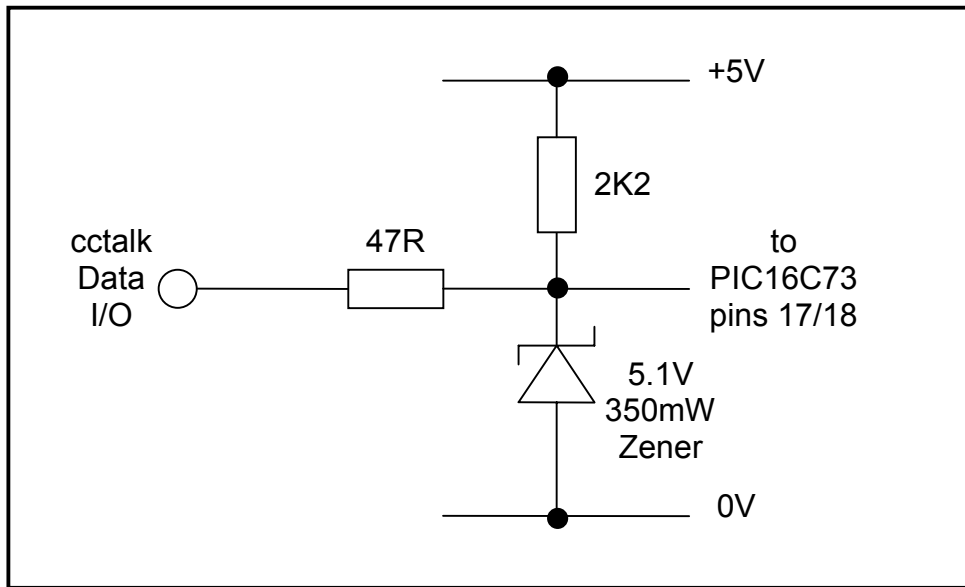

Figure 3: ccTalk<sup>®</sup> Interface Circuit:

## 25. Appendix D

### 25.1 NV Memory Map Description

*Table 12: NV Memory Map Description:.*

Block No.	Length Bytes	Description	Read / Write Permission
0	8	User data	R / W
1	6	Coin name	R / W
1	2	User data	R / W
2	3	Hopper dispense count	R / W
2	1	Checksum A	R / W
2	1	Last payout : coins paid	R / W
2	1	Checksum B	R / W
2	1	Last payout : coins unpaid	R / W
2	1	Checksum C	R / W
3	3	Hopper life dispense count	Read Only
3	1	Checksum D	Read Only
3	1	Black Box Recorder A	Read Only
3	1	Black Box Recorder B	Read Only
3	1	Black Box Recorder C	Read Only
3	1	Black Box Recorder D	Read Only

#### **User data**

10 bytes of user data are available to the host machine for any kind of storage requirement. The data can be ASCII text or binary data - there is no restriction on format. All 8 bytes of block 0 are available, together with the top 2 bytes of block 1.

#### **Coin name**

The name of the hopper coin, if programmed. Users can program their own coin names. The ASCII string stored in these locations is returned by the 'Request hopper coin' command.

#### **Hopper dispense count**

The total no. of coins dispensed since the counter was reset.

Note that the cctalk command 'Request hopper dispense count' should be used to read the value of this counter. The value in EEPROM is not updated until power-down or reset.

#### **Last payout : coins paid**

The no. of coins dispensed by the last command.

Continued...

---

CONFIDENTIAL

Not to be disclosed without prior written permission from Money Controls

Page 50 of 53

**Last payout : coins unpaid**

The no. of coins which failed to be dispensed by the last command.

**Hopper life dispense count**

The total no. of coins dispensed since the product was manufactured.

Note that the life dispense count is **only updated** when the NV Memory is updated - i.e. when power is removed or at reset. It does not hold a running count value like the 'hopper dispense count'.

**Checksums and Black Box Recorders**

Each counter is protected by a null checksum such that the 8-bit addition of all counter bytes and the checksum byte is zero.

If the software detects a checksum fail then the corresponding checksum error flag is set ( refer to the 'Test hopper' command ) and the black box recorder byte is incremented. The black box recorder bytes are used to monitor problems with the power-fail electronics.

**Example - Clearing the Hopper dispense count**

This can be achieved by reading block 2 and writing it back with the appropriate bytes cleared to zero.

Complete message packets shown. Data values in decimal. Hopper is address 3.

**Read Cycle**

TX : [ 3 ][ 1 ][ 1 ][ 215 ][ 2 ][ checksum ] - Read block 2

RX : [ 1 ][ 8 ][ 3 ][ 0 ][ count 1 ][ count 2 ][ count 3 ][ count checksum ]  
[ data 1 ][ data 2 ][ data 3 ][ data 4 ][ checksum ]

**Write Cycle**

TX : [ 3 ][ 9 ][ 1 ][ 214 ][ 2 ][ 0 ][ 0 ][ 0 ][ 0 ] - Write block 2  
[ data 1 ][ data 2 ][ data 3 ][ data 4 ][ checksum ]

RX : [ 1 ][ 0 ][ 3 ][ 0 ][ 252 ] - ACK

## 26. Appendix E

### Request Hopper Status Examples

The reply from the 'Request hopper status' command is...

[event counter] [payout coins remaining] [last payout : coins paid] [last payout : coins unpaid]

#### **Dispense 1 coin in single coin mode**

```
Hopper status = 01 01 00 00
Hopper status = 01 01 00 00
Hopper status = 01 01 00 00
Hopper status = 01 00 01 00 Paid 1 coin
```

#### **Dispense 5 coins in multi-coin mode**

```
Hopper status = 02 05 00 00
Hopper status = 02 05 00 00
Hopper status = 02 04 01 00
Hopper status = 02 04 01 00
Hopper status = 02 03 02 00
Hopper status = 02 03 02 00
Hopper status = 02 02 03 00
Hopper status = 02 02 03 00
Hopper status = 02 01 04 00
Hopper status = 02 01 04 00
Hopper status = 02 00 05 00 Paid 5 coins
```

#### **Dispense 5 coins in multi-coin mode. Only 2 coins in hopper**

```
Hopper status = 03 05 00 00
Hopper status = 03 04 01 00
Hopper status = 03 03 02 00
Hopper status = 03 03 02 00
Hopper status = 03 03 02 00
Hopper status = 03 03 02 00
Hopper status = 03 03 02 00
Hopper status = 03 03 02 00
Hopper status = 03 03 02 00
Hopper status = 03 03 02 00
Hopper status = 03 03 02 00
Hopper status = 03 03 02 00
Hopper status = 03 03 02 00
Hopper status = 03 03 02 00
Hopper status = 03 01 01 03 Partial result - ignore
Hopper status = 03 00 02 03 Paid 2 coins, 3 remaining
```

---

CONFIDENTIAL

Not to be disclosed without prior written permission from Money Controls

Page 52 of 53

This manual is intended only to assist the reader in the use of this product and therefore Money Controls shall not be liable for any loss or damage whatsoever arising from the use of any information or particulars in, or any incorrect use of the product. Money Controls reserve the right to change product specifications on any item without prior notice.

---

CONFIDENTIAL

Not to be disclosed without prior written permission from Money Controls  
Page 53 of 53