

HUB BOARD

FOR USE WITH PROTOCOL CCTALK

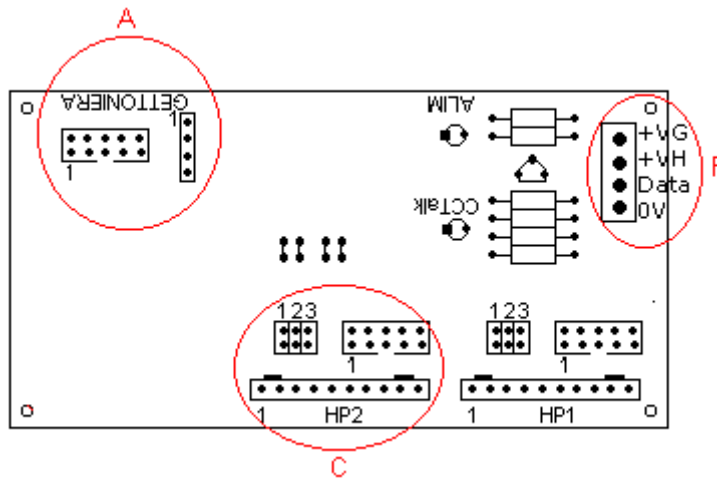

**PRODUCT CODE
CM/HUBCCTALKRID**

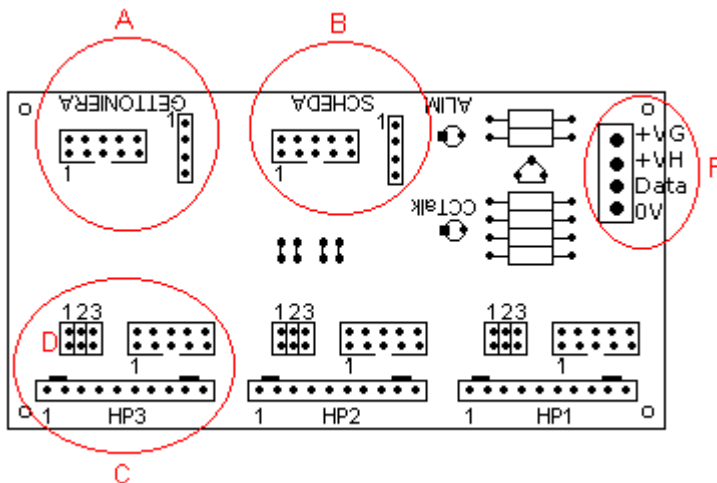

**PRODUCT CODE
CM/HUBCCTALK**

The HUB board has been made to facilitate connection with existing peripherals on a game machine. It has been produced in two versions.

Compact Version (CM/HUBCCTALKRID) provides two aligned connectors for hoppers, two 5x2 connectors for hoppers, a 5x2 connector for coin validator, a 4 pin jst connector for coin validator, a clamp.

Complete Version(CM/HUBCCTALK) provides a third aligned connector for hoppers, a third 5x2 connector for hoppers, a 4 pin jst for game board and a 5x2 connector for game board.

Basic elements can be connected to the board to form the machine.

Coin Validator

The coin validator can be connected using a ten Pin flat cable connector or a four Pin connector (A)

Game Board

The board has to supplied by a four Pin clamp (OV and +V)and can be connected by a ten Pin flat cable, using a four Pin (B) or connecting the Data line to the four Pin clamps. (F)

Hoppers

Each hopper (max three) can be connected by the ten Pin aligned connector or using a ten Pin flat cable connector (C). For each hopper it is possibile to choose the desired address using the appropriate jumpers (D), see table below.

PIN1	PIN2	PIN3	ADDRESS
			3
		X	4
	X		5
	X	X	6
X			7
X		X	8
X	X		9
X	X	X	10

Supply

The four pin clamp (F) allows two different suppli systems one for the coin validator (VG)) and one for the hoppers (VH), using an external suppli system.

Use suitable cables.

- If hoppers and coin validators need 24V, it will be sufficient to connect clamp 2 (V Hoppers) to clamp 1 (V Coin validator) as shown in cablegram 1.
- If hoppers and coin validators need 12V, it will be sufficient to connect clamp 1 (V coin validator) to clamp 2 (V Hoppers) as shown in cablegram 2.
- If the coin validator works with 12V and the Hoppers with 24V it is necessary to connect the 12V to clamp 1 (V coin validator) and the 24V to clamp 2 (V hoppers) as shown in cablegram 3.
- If the coin validator has to work with 24V and the Hoppers with 12V it is necessary to connect the 24V to clamp 1 (V coin validator) and the 24V to clamp 2 (V Hoppers) as shown in cablegram 4.

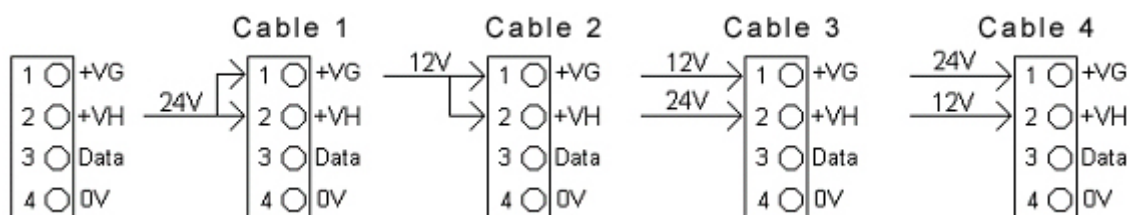

The same clamp can also be used to connect Jamma directly to I bus CCTALK .