

Innovative Technology Limited ®

NV10 Bank Note Validating System

The Future of Smiley® Bank Note Handling



Operations Manual

GA333-3

© Copyright Innovative Technology Limited 2005

CONTENTS

| | |
|---|-----------|
| CONTENTS | 2 |
| Change History | 3 |
| 1: Introduction | 4 |
| 2: Scope of Document | 5 |
| 3: General Description | 6 |
| 4: Environment and Power Requirements | 7 |
| 5: NV10 User Interface | 8 |
| 5.1: <i>DIPswitch Settings</i> | 8 |
| 5.2: <i>LED status codes</i> | 9 |
| 6: Machine Interface: Hardware | 10 |
| 6.1: <i>Interface Connector Pin Details</i> | 10 |
| 6.2: <i>Input and Output Hardware Circuits</i> | 11 |
| 6.3: <i>Software Optional Serial Interface Input and Outputs</i> | 11 |
| 7: Machine Interface: Protocols | 12 |
| 7.1: <i>Parallel input and output</i> | 12 |
| 7.2: <i>Pulse Stream Output</i> | 12 |
| 7.3: <i>Binary Output</i> | 13 |
| 7.4: <i>Simple Serial Input/Output</i> | 14 |
| 7.5: <i>Smiley® Secure Protocol – SSP</i> | 17 |
| 7.6: <i>MDB – Multi-Drop Bus / Internal Communications Protocol (IF5)</i> | 18 |
| 7.7: <i>CCTalk Protocol</i> | 20 |
| 7.8: <i>Extended Interface – USA Serial</i> | 21 |
| 8: Updating Currency and Firmware | 22 |
| 8.1: <i>Currency Manager</i> | 22 |
| 8.2: <i>NV10 – NV10 Copy (Cloning)</i> | 22 |
| 8.3: <i>NV10 – NV10 copy process</i> | 23 |
| 9: Mechanical Installation | 24 |
| 9.1: <i>Changing or removing the bezels:</i> | 24 |
| 9.2: <i>Fitting the bezel into a machine</i> | 24 |
| 9.3: <i>Cash Box Interface</i> | 24 |
| 10: Routine Maintenance | 26 |
| 10.1: <i>Cleaning</i> | 26 |
| 10.2: <i>Belt Changing</i> | 27 |
| 11: Fault Finding Analysis | 28 |
| 12: Support Tools | 30 |
| 12.1: <i>PC Currency Programming Software</i> | 30 |
| 12.2: <i>Internet Website support</i> | 30 |
| 12.3: <i>E-mail Support</i> | 30 |
| Appendix A – Dimension Drawing | 31 |
| Appendix B – Extended Bezel | 32 |
| Appendix C – Cash Box Advice | 33 |
| Appendix D - ESCROW Control | 34 |
| Appendix E - Interface Tools DA1 - DA2 | 35 |
| Appendix F – Website Registration | 36 |

Change History

| Innovative Technology Ltd | | | |
|----------------------------------|-----------------|------------------------------|-----------------|
| Title: | | NV10 Engineers Manual | |
| Drawing No: | | Project: | |
| Author: T.J. Crowley | | Date: 20/07/2005 | |
| Format: | | MS Word 2000 | |
| Issue | Rel Date | Mod By | Comments |
| Issue 1 | 20/07/2005 | CC | First draft |
| Issue 2 | 08/08/2005 | RJS | Second Draft |
| Issue 3 | 05/09/2005 | RJS | Initial Release |

1: Introduction

This manual describes the operation of the NV10 Bank note Validator as fitted with Firmware Version 3.15 or greater.

Caution

- This Product must be fitted with a 2 Amp fuse before use.
- The NV10 Validator is pin for pin compatible with NV7/8/9, but **NOT** pin for pin compatible with the NV2/3/4/4X or 5 series products.

We recommend that you study this manual as there are many new features permitting new uses and more secure applications.

If you do not understand any part of this manual please contact ITL for assistance. In this way we may continue to improve our product. Alternatively visit our web site at www.innovative-technology.co.uk

Innovative Technology Ltd.
Derker Street
Oldham
England
OL1 4EQ
Tel: +44 (0) 161 626 9999
Fax: +44 (0) 161 620 2090
E-mail support@innovative-technology.co.uk
Web site www.innovative-technology.co.uk

Smiley® and the ITL Logo are international registered trademarks and they are the property of Innovative Technology Limited.

Innovative Technology has a number of European and International Patents and Patents Pending protecting this product. If you require further details please contact the factory.

Innovative Technology is not responsible for any loss, harm, or damage caused by the installation and use of this product. This does not affect your local statutory rights. If in doubt please contact Innovative Technology for details of any changes

2: Scope of Document

This document is intended for those whose will:

- Design the NV10 into items of equipment.
- Build equipment using the NV10.
- Install equipment containing the NV10.
- Maintain equipment containing the NV10.

Although information is included which will allow a degree of fault diagnosis and repair, it is recommended that for all but simple mechanical repairs the unit be returned to an approved service centre for repair.

Caution:

- Never exceed the recommended environmental and electrical limits.
- Do not attempt to lubricate the mechanisms as this may affect the note transport.
- Do not polish the lens as this may alter the optical characteristics.
- If the NV10 Validator is disassembled the unit must be re-calibrated/re initialised, following re-assembly.

Innovative Technology Ltd has a policy of continual product improvement. As a result the products supplied may vary from the specification described here.

3: General Description

NV10 Validator - the next generation of Smiley® Bank Note validators

The NV10 Bank Note Validator is a compact note-validating machine (see figure 1), suitable for most money machines. It will accept up to 15 different denominations of notes in the serial control mode, pulse mode and binary mode, 4 notes in parallel mode and will cope with different designs of banknotes having the same value such as are found in the United Kingdom.

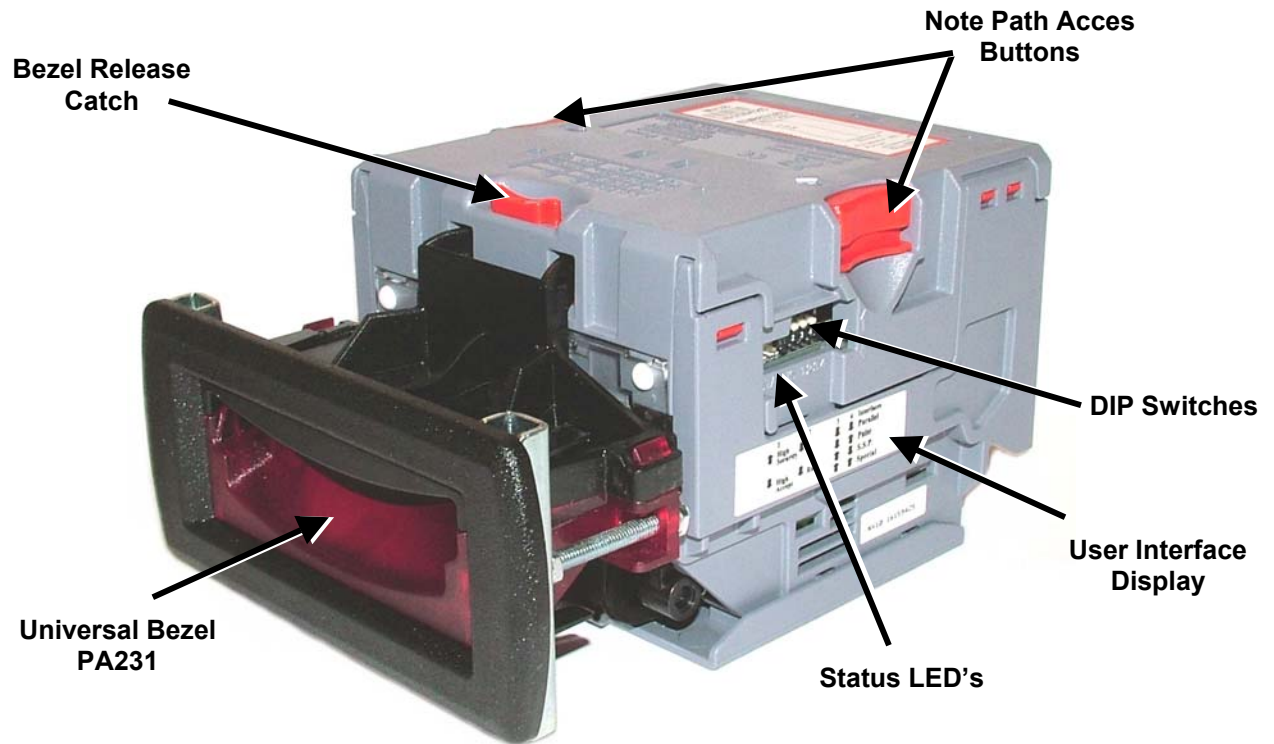

Figure 1 – The NV10 and Universal Bezel PA231

The NV10 Validator leaves the factory containing at least one currency data set so that it is ready for immediate installation. If it is desired to change the currency data set this may be done using either the NV10 to NV10 currency cloning system or the PC based Currency Management software.

New currencies and applications are being tested all the time, please refer to our web site or contact the factory for information concerning specific currencies if they are not already included on our approved list.

The NV10 has been designed for easy installation in most machines. The new stepped “smiling mouth” allows insertion of notes with one hand and simplifies the note handling mechanism.

Interfacing the Validator is very simple, with the choice of the following protocols:

- Parallel open collector outputs
- Pulse stream output
- Smiley® Secure Protocol (SSP) secure serial communications
- Binary
- Simple serial communications
- CCTalk
- MDB interface protocol
- Extended Interface / USA Serial

4: Environment and Power Requirements

| Environment | Minimum | Maximum |
|-------------|---------|--------------------|
| Temperature | +0°C | +50°C |
| Humidity | 5% | 95% Non condensing |

Table 1 - Environmental Requirements

Caution:

- If the input voltage falls below 11V the NV10 may not operate correctly (will reject notes). The amber status LED and front bezel lights will flash to indicate incorrect conditions
- It is recommended that the power supply used can supply at least 1.5Amps.

| Electrical Supply | Minimum | Maximum |
|---------------------------------------|---------|--------------|
| Supply Voltage (V dc) Absolute Limits | 11V | 15V |
| MDB IF5 Version Supply Voltage | 18V | 42V |
| Supply Ripple Voltage | | 0.25V @100Hz |
| Supply Currents: | | |
| Standby | | 0.35A |
| Validating | | 1A |
| Peak | | 1.5A |

Table 2 - Power Requirements

5: NV10 User Interface

The user interface with the NV10 is shown below (see figure 2). It is simply a red and green LED and a set of four DIPswitches. The LED's indicate the operational status of the NV10, while the DIPswitches set the basic operating mode of the unit.

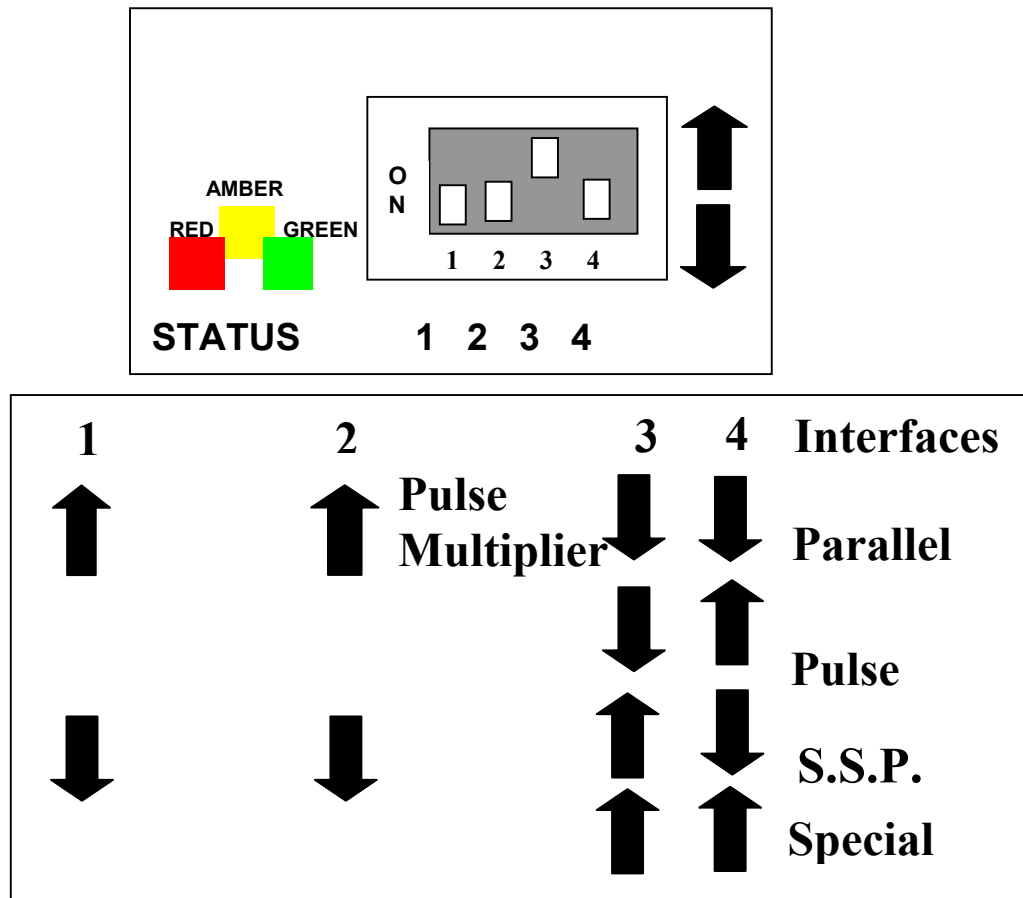



Figure 2 – NV10 User Display and DIPswitches

5.1: DIPswitch Settings.

The four DIPswitches can be set to a combination of either up  or down  depending on the configuration required for the particular NV10.

Switch 1 – Spare

Switch 1 currently has no function and is reserved for future use.

Switch 2 – pulse multiplier

This switch is used to modify the behaviour of the selected machine interface. Details of the function of this switch are covered in the interfaces' description in this manual.

Currently the only interface to make use of this switch is the pulse mode. In this mode the switch can be used to multiply the number of pulses given by a factor of four. When the switch is down the multiplier is 1, when the switch is up the multiplier is 4.

Switches 3 and 4 – Machine Interface protocol selection

These switches are used to select the machine interface to be used. The NV10 supports four interfaces, as shown below, (see table 1).

NV10 Operations Manual – GA333-3

| Interface | Switch 3 | Switch 4 |
|-----------------|----------|----------|
| Parallel | Down | Down |
| Pulse | Down | Up |
| SSP | Up | Down |
| Special | Up | Up |

Table 1 – Switch 3 and 4 Machine Interface Selection

The details of the parallel, pulse and SSP can be found in the machine interface protocol section of this manual.

The special interface depends on the firmware that is used in the NV10, the firmware shipped as standard is the binary interface (World Wide) and CCTalk (UK only). However there are other options that can be downloaded by the user:

- CCTalk.
- ITL Simple serial I/O.
- Binary
- MDB

Information on each of these interfaces can be found in the 'machine interfaces protocol section' of this manual.

5.2: LED status codes.

The three status LED's are located to the left of the DIPswitches on the right hand side of the unit and are used to indicate a variety of status signals.

The red status is used to indicate system problems, while the green status indicates system health, these are described below in table 2.

| LED Status | Description |
|---|--|
| Slow flashing green led Heartbeat (Slow = 1 second period) | In normal RUN operation, when the NV10 is ready to read a note, the green status led will flash slowly ("Heartbeat") to signal a "healthy" status. |
| Flashing red one second period | NV10 is jammed, somewhere in the note path |
| Fast flashing red (fast = half second period) | NV10 cannot calibrate, sensor(s) may be blocked |
| Permanent Red | Memory has been corrupted |
| Flashing amber and bezel lights | Power supply is incorrect, check specification |

Table 2 - LED Status Codes

6: Machine Interface: Hardware.

The NV10 interface connector is located on the left side of the unit. It has 16 pins (see figure 3), two are used for the 0v and +12v power supply and there are five outputs and five inputs, the remaining four pins are reserved for future use. An example mating connector is Molex Part No: 39-51-2160

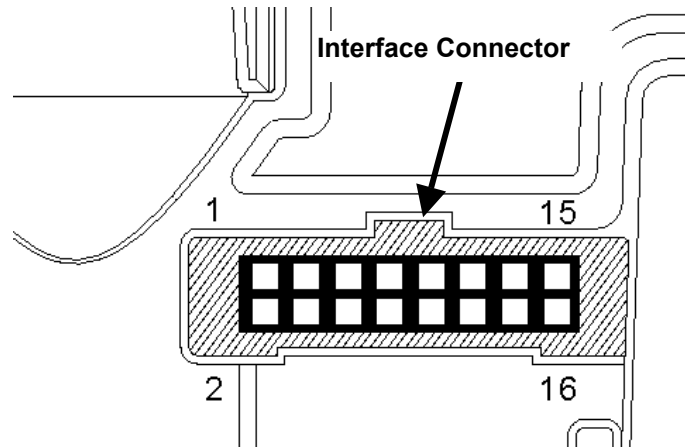

Figure 3 - Interface Connector

6.1:Interface Connector Pin Details

The interface connector pins details are described below (see table 3); they have a 0.1" pitch header with 2 rows of 8 pins.

| Pin | Name: | Description: |
|-----|-----------------------|--|
| 1 | Vend 1 (binary bit 1) | Note accepted on Channel 1, Also the Pulse Stream output Also the serial output pin in SSP and other serial modes |
| 2 | Vend 2 (binary bit 2) | Note accepted on Channel 2 pulse output |
| 3 | Vend 3 (binary bit 4) | Note accepted on Channel 3 pulse output |
| 4 | Vend 4 (binary bit 8) | Note accepted on Channel 4 pulse output |
| 5 | Inhibit 1 | Inhibit channel 1 by holding this pin HIGH. To Enable a channel the inhibit must be held LOW. Also the Serial Input pin for SSP and other serial modes. |
| 6 | Inhibit 2 | Inhibit channel 2 by holding this pin HIGH |
| 7 | Inhibit 3 | Inhibit channel 3 by holding this pin HIGH |
| 8 | Inhibit 4 | Inhibit channel 4 by holding this pin HIGH |
| 9 | Busy | NV8 is validating and stacking output. Active low while the NV8 is reading, transporting or stacking a note. |
| 10 | Escrow | Operate Escrow function by holding LOW, refer to Escrow section in parallel and binary modes and Appendix D for full details |
| 11 | Spare | Spare |
| 12 | Spare | Spare |
| 13 | Spare | Spare |
| 14 | Spare | Spare |
| 15 | +Vin | Nominal 12V DC supply |
| 16 | 0V | 0v Supply |

Table 3 - 16 Pin Connector Details

6.2: Input and Output Hardware Circuits

Caution: The output low signal is affected by the value of the pull up resistor on the host machine interface. Ensure your signal LOW levels comply with the 74HC CMOS series specification for reliable operation, (see figure 4).

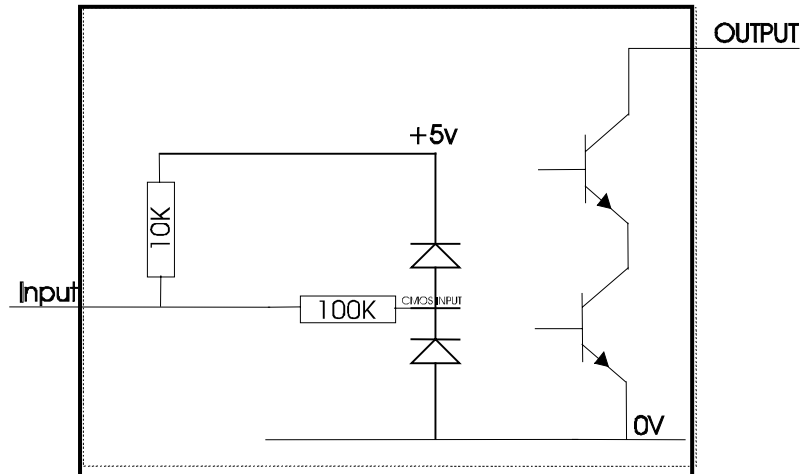

Figure 4 - Input and Output Circuit

- All outputs are open collector transistors.
- All Inputs are held high to internal +5v via 10KΩ. The input structure is a CMOS gate with anti static protection fitted.

| Interface Logic levels | Logic Low | Logic High |
|---------------------------|-----------------|-----------------------------------|
| Inputs | 0V < Low < 0.5 | +3.7V < High < 12V |
| Outputs with 2K2Ω pull up | 0.6V | Pull up voltage of host interface |
| Maximum Current Sink | 50mA per output | |

Table 4- Interface Logic Levels

6.3: Software Optional Serial Interface Input and Outputs

Caution: The serial interfaces will only work if the relevant interface software is correctly installed.

| Name | Description |
|---------|-------------|
| SSP TxD | Vend 1 |
| SSP RxD | Inhibit 1 |

Table 5 - Software Optional Serial Interface Inputs and Outputs

7: Machine Interface: Protocols

To select the required interface, the DIPswitches on the side of NV10 need to be set accordingly:

7.1: Parallel input and output

To use parallel outputs DIPswitches 3 and 4 must be set down.

Vend Signals: (Pins 1 to 4). The four channels have their own individual outputs. If a note is recognised then the relevant channel line is set low for 100 ± 3 milliseconds. Pulses outside these limits should be rejected as a precaution against false triggering due to noise.

Busy Output: (Pin 9). This is a general-purpose busy signal. It is active low while the NV10 is in operation.

Escrow Control (Pin 10)-Parallel mode: The NV10 uses a single note escrow facility in this mode (see [Appendix D](#)): This allows the Validator to hold onto the note once accepted, and then only stack the note in the cash box when the host machine confirms that the Vend operation has been completed. If confirmation of the Vend is not received the note will be returned to the customer after 30 seconds.

If the host machine aborts the transaction by setting the corresponding inhibit input high, the note is returned immediately.

The host machine can force the return of the note to the customer by setting the inhibit line high, at any time before the end of the 30 second time-out. Setting all the inhibits high will cause a note reject.

In the event of a note being forcibly removed from the mouth of the NV10 during the 30 second interval, the NV10 will go out of service for 45 seconds.

Inhibit Operation

Each channel (1 to 4) has its own inhibit input to allow the host machine to refuse specified notes. To inhibit a channel, the relevant inhibit input must be held high. To enable a channel the corresponding inhibits must be latched low so that notes may be accepted.

If all four inhibits are high simultaneously then the NV10 will not read in any notes. In this mode, if a note is inserted the motor will run in reverse preventing the insertion of a note and the bezel will not illuminate.

All four inhibits may be connected together to create a 'global' inhibit. In this way the NV10 may be brought in and out of operation by the host machine.

7.2: Pulse Stream Output

To use pulse stream output for acceptance of up to 16 channel / note acceptance, DIP switch 3 must be down and DIP switch 4 must be up.

Vend Signal (Pins 1): When a note is recognised vend 1 will pulse a pre set number times, the number of pulses and the timing is set in the NV10 currency manager program (and set to default values with supplied dataset).

The number of pulses is multiplied by a factor of four for USA Dollar datasets, depending on the position of switch 2. If the switch is down then the number of pulses is as programmed in the dataset output. If the switch is up then four times this number of pulses is output.

Busy Output: (Pin 9). This is a general-purpose busy signal. It is active low while the NV10 is in operation.

Escrow Control: (pin 10). The NV10 uses a single note escrow facility in this mode (see [Appendix D](#)): This allows the Validator to hold onto the note once accepted, and then only stack the note in the cash box when the host machine confirms that the Vend operation has been completed. If confirmation of the Vend is not received the note will be returned to the customer after 30 seconds.

If the host machine aborts the transaction by setting the corresponding inhibit input high, the note is returned immediately.

The host machine can force the return of the note to the customer by setting the inhibit line high, at any time before the end of the 30 second time-out. Setting all the inhibits high will cause a note reject.

In the event of a note being forcibly removed from the mouth of the NV10 during the 30 second interval, the NV10 will go out of service for 45 seconds.

Inhibit Operation: Channels (1 to 4) have their own individual inhibit input to allow the host machine to refuse specified values of notes. To inhibit a channel, the relevant inhibit input must be held high. To enable a channel the corresponding inhibit must be latched low so that notes may be accepted.

Note: Channels higher than four cannot be individually inhibited, but will be globally inhibited if inhibits 1 to 4 are inhibited.

If all four inhibits are high simultaneously then the NV10 will not read in any notes. All four inhibits may be connected together to create a 'global' inhibit. In this way the NV10 may be brought in and out of operation by the host machine.

7.3: Binary Output

To use binary output DIP switches 3 & 4 must both be up and the BIN option of the interface firmware must be loaded into the NV10.

In the event that the machine needs more than 4 notes to be recognised, but the host machine cannot take advantage of the serial communication methods then the NV10 can be set to give a binary pattern output on the four parallel output pins.

If the NV10 is set to binary mode it will issue the vend signals as a binary pattern on the parallel outputs for 100 ± 3 ms. In this way a maximum of 15 different notes can be accepted and 4 notes individually inhibited.

Vend Signals (Pins 1 to 4). The four channels have their own individual outputs. If a note is recognised then the binary representation of the channel number will be pulled low for 100 ± 3 ms. Pulses outside these limits will be rejected as a precaution against false triggering due to noise.

Busy Output: (Pin 9). This is a general-purpose busy signal. It is active low while the NV10 is in operation.

Escrow Control: (pin 10). The NV10 uses a single note escrow facility in this mode (see [Appendix D](#)). This allows the Validator to hold onto the note once accepted, and then only stack the note in the cash box when the host machine confirms that the Vend operation has been completed. If confirmation of the Vend is not received the note will be returned to the customer after 30 seconds.

If the host machine aborts the transaction by setting the corresponding inhibit input high on pin 10, the note is returned immediately.

The host machine can force the return of the note to the customer by setting the inhibit line high, at any time before the end of the 30 second time-out. Setting all the inhibits high will cause a note reject.

In the event of a note being forcibly removed from the mouth of the NV10 during the 30 second interval, the NV8 will go out of service for 45 seconds.

Inhibit Operation: Channels (1 to 4) have their individual inhibit input to allow the host machine to refuse specified notes. To inhibit a channel, the relevant inhibit input must be held high. To enable a channel the corresponding inhibit must be latched low so that notes may be accepted.

Note: Channels higher than four cannot be individually inhibited, but will be globally inhibited if inhibits 1 to 4 are inhibited.

If all four inhibits are high simultaneously the NV10 will not read notes. All 4 inhibits connected together create a 'global' inhibit. This way the NV10 may be brought in and out of operation by the host machine.

7.4: Simple Serial Input/Output

Existing Smiley® NV4 users may already be using the serial input/output facility. The NV10 Validator also supports this system. However this interface is not recommended for new designs, the Smiley® Secure Protocol SSP interface is recommended.

Caution:

- The NV10 **does not** support the Simple serial data out only mode as available on NV4. It only supports the serial data Input/Output mode.
- The host machine does not echo messages back to the Validator.
- The NV10 **does not** operate in true RS232 mode.
- The NV10 will not enable in serial I/O mode if Inhibit 3 line is held low on power up

To use simple serial mode DIPswitches 3 & 4 must both be set up and the Simple Serial mode SIO option of the interface firmware must be loaded into the NV10.

Commands are provided to fully control the operation of the validator. The notes to be accepted and rejected can be set and a single escrow mode can be enabled. In simple serial mode single byte commands are transmitted to the Validator, the Validator echoes each valid command it receives.

The serial I/O mode supports two baud rates; 300 baud when Inhibit 2 is pulled high or left floating at power up and 9600 Baud rate when Inhibit 2 line is held low at power up. The data is formatted as follows (see figure 6):

1-start bit - 8 data bits - 2 stop bits - 300 baud

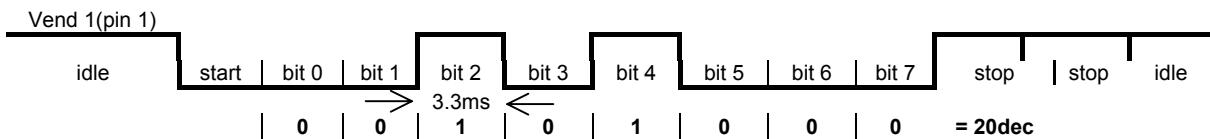

Figure- 6 Typical Serial Output Transmission of the value 20 (decimal), Note Not Recognized

NV10 Operations Manual – GA333-3

The NV10 will receive and transmit the following event codes:

| Recognised Receive Codes to NV10 | | Transmitted codes from NV10 | |
|----------------------------------|---------------|---|---------------|
| MESSAGE | DECIMAL VALUE | MESSAGE | DECIMAL VALUE |
| Inhibit C1 | 131 | Note Accept on C1 | 1 |
| Inhibit C2 | 132 | Note Accept on C2 | 2 |
| Inhibit C3 | 133 | Note Accept on C3 | 3 |
| Inhibit C4 | 134 | Note Accept on C4 | 4 |
| Inhibit C5 | 135 | Note Accept on C5 | 5 |
| Inhibit C6 | 136 | Note Accept on C6 | 6 |
| Inhibit C7 | 137 | Note Accept on C7 | 7 |
| Inhibit C8 | 138 | Note Accept on C8 | 8 |
| Inhibit C9 | 139 | Note Accept on C9 | 9 |
| Inhibit C10 | 140 | Note Accept on C10 | 10 |
| Inhibit C11 | 141 | Note Accept on C11 | 11 |
| Inhibit C12 | 142 | Note Accept on C12 | 12 |
| Inhibit C13 | 143 | Note Accept on C13 | 13 |
| Inhibit C14 | 144 | Note Accept on C14 | 14 |
| Inhibit C15 | 145 | Note Accept on C15 | 15 |
| Inhibit C16 | 146 | Note Accept on C16 | 16 |
| Un-inhibit C1 | 151 | Note Not Recognised | 20 |
| Un-inhibit C2 | 152 | Mechanism running slow | 30 |
| Un-inhibit C3 | 153 | Strimming attempted | 40 |
| Un-inhibit C4 | 154 | Channel 5 Note Rejected (fraud channel) | 50 |
| Un-inhibit C5 | 155 | STACKER Full or Jammed | 60 |
| Un-inhibit C6 | 156 | Abort During Escrow | 70 |
| Un-inhibit C7 | 157 | Note may have been taken to clear jam | 80 |
| Un-inhibit C8 | 158 | Validator Busy | 120 |
| Un-inhibit C9 | 159 | Validator Not Busy | 121 |
| Un-inhibit C10 | 160 | Command Error | 255 |
| Un-inhibit C11 | 161 | | |
| Un-inhibit C12 | 162 | | |
| Un-inhibit C13 | 163 | | |
| Un-inhibit C14 | 164 | | |
| Un-inhibit C15 | 165 | | |
| Un-inhibit C16 | 166 | | |
| Enable serial escrow mode | 170 | | |
| Disable serial escrow mode | 171 | | |
| Accept Escrow | 172 | | |
| Reject Escrow | 173 | | |
| Status | 182 | | |
| Enable all | 184 | | |
| Disable all | 185 | | |
| Disable escrow timeout | 190 | | |
| Enable escrow timeout | 191 | | |

Table 6 - Receive and Transmit Codes

NV10 Operations Manual – GA333-3

Example transactions are shown below (see table 7).

| Event | Validator | Decimal Value | Host |
|---|--|--|-----------------------|
| Note entered into validator Note Accepted Channel 2 | Validator Busy Validator Ready Accept on Channel 2 | 120 → 121 → 2 → | |
| Note entered into validator Note not recognised Validator has returned note | Validator Busy Validator Ready Note not recognised Validator Ready | 120 → 121 → 20 → 121 → | |
| Software Inhibit Channel 4 | Inhibit C4 Channel 4 Inhibited | ← 134 134 → | Inhibit C4 |
| Software Enable Channel 4 | Uninhibit C4 Channel 4 Inhibited | ← 154 154 → | Uninhibit C4 |
| Status Report 3 byte status message | Inhibit status Channels 1-8 Inhibit status Channels 9-16 Escrow On (=1) / Off (=0) | ← 182 byte 1 → byte 2 → byte 3 → | Status Request |
| Turn on Escrow Mode | Escrow Mode Enabled | ← 170 170 → | Enable Escrow Mode |
| Note accept in Escrow Mode Note entered into validator Note Accepted Channel 2 | Validator Busy Validator Ready Accept on Channel 2 Accept Escrow Accept on Channel 2 | 120 → 121 → 2 → ← 172 172 → 2 → | Accept Note in Escrow |

Table 7 - Example Protocols

7.5:Smiley® Secure Protocol – SSP

Note: Please refer to the Smiley® Secure Protocol (SSP) Specification (ITL Drawing GA138) on the web site for full details of this Protocol.

To use SSP mode DIP switch 3 must be set up and DIP switch 4 must be set down.

SSP is a secure serial interface specifically designed to address the problems experienced by cash handling systems in gaming machines. Problems such as acceptor swapping, reprogramming acceptors and line tapping are all addressed. This interface is recommended for all new designs.

The interface uses a master slave model, the host machine is the master and the peripherals (note acceptor, coin acceptor or coin hopper) are the slaves.

Data transfer is over a multi-drop bus using clock asynchronous serial transmission with simple open collector drivers. The integrity of data transfers is ensured through the use of 16 bit CRC checksums on all packets.

Each SSP device of a particular type has a unique serial number, this number is used to validate each device in the direction of credit transfer before transactions can take place .

Commands are currently provided for coin acceptors, note acceptors and coin hoppers. All current features of these devices are supported.

Features:

- Serial control of Note / Coin Validators and Hoppers
- 4 wire (Tx, Rx, +V, Gnd) system
- RS232 (like) - open collector driver
- High Speed 9600 Baud Rate
- 16 bit CRC error checking
- Data Transfer Mode

Benefits:

- Proven in the field
- Simple and low cost interfacing of transaction peripherals.
- High security control of payout peripherals.
- Defence against surrogate validator fraud.
- Straightforward integration into host machines.
- Remote programming of transaction peripherals
- Open standard for universal use.

For detailed information and full protocol specification please refer to SSP Specification ITL Drawing GA 138, this is available from the ITL website www.innovative-technology.co.uk

To help in the software implementation of the SSP, ITL can provide sample C Code, DLL controls and Visual Basic applications on request. Please contact support@innovative-technology.co.uk.

7.6: MDB – Multi-Drop Bus / Internal Communications Protocol (IF5)

To use the MDB mode an IF5 interface box must be fitted to the NV10 Validator and DIPswitches 3 & 4 must both be set up, with the MDB option of the interface firmware loaded into the NV10.

Note:

- Please refer to the Multi-Drop Bus specification for the suggested current drive circuits available.
- The NV10 supports the MDB protocol version 1, level 1
- For detailed information and full protocol specification please refer to NAMA (www.vending.org)

MDB defines a serial bus interface used in electrically controlled vending machines (see figure 7). This is a 9600 Baud Master-Slave system where the NV10 MDB banknote validator is a slave to a master controller. A master has the capability of communicating with 32 peripherals or slaves. The master is defined as the Vending Machine Controller (VMC).

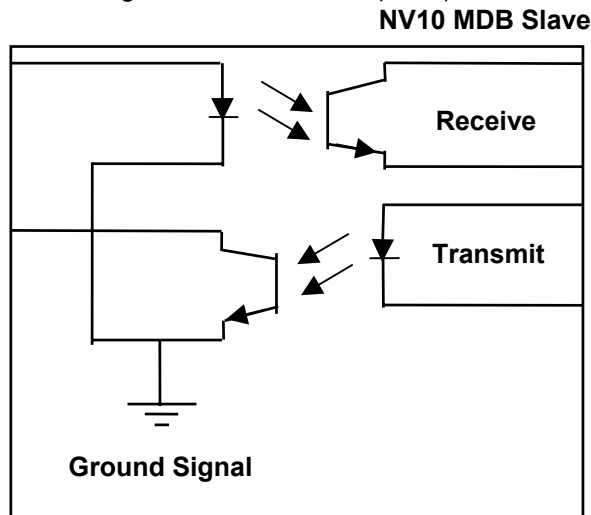

Figure 7- MDB Opto Isolated Input / Output circuits

The NV10 MDB banknote Validator is assigned a unique address – 00110XXX binary (30H). The VMC polls the bus to detect presence of the NV10 MDB Validators or to get information on current status of the Validators.

The Validators respond when asked for activity with an acknowledgment, negative acknowledgment or a specific reply, depending on its current status. Bus crashes are avoided as the Validators respond to being polled only by the VMC.

The international country code must be set for the country in which the Validators will be operating. This is the international telephone code for that country. The code is represented as two bytes

For the USA the country code is 00 01

For Great Britain the code is 00 44

The scaling factor must also be specified for each Validator. All accepted note values must be evenly divisible by this number.

- This number would be set to 100 (Hex 64) for the Euro or Great Britain.
- The number would be set to 1000 (Hex 03E8) for Romania.
- The number of decimal places must also be programmed for each Validators
- The number would be set to 2 for Euro or USA
- The number would be set to 3 for Romania

Adopting the numbers above:

- £5 would be displayed as 5.00
- £10 would be displayed as 10.00
- \$1 would be displayed as 1.00
- 1K Romania would be displayed as 1.000

7.7: CCTalk Protocol.

The NV10 supports the CCTalk serial protocol for easy interfacing with host machines that support this protocol.

To use CCTalk mode (as in Binary mode etc) set DIPswitches 3 and 4 on the user in the Up position to select 'Special' mode on the validators.

The NV8 must have the CCTalk software loaded using the "advanced" option on the Currency manager program.

Pin out connections on NV10 for CCTalk are shown below (see figure 7) looking at the connection pins on the NV10 interface connector.

Note:

- For detailed information and full protocol specification please refer to www.cctalk.org

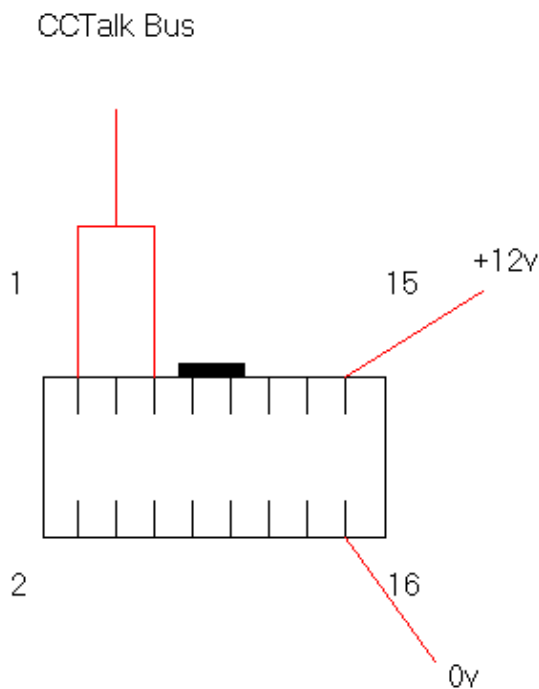

Figure 7- CCTalk Connection Pins on the NV10.

The default encryption key will be set to the key code printed on the label on the NV10. If the key is changed to a new stored key by the host machine, the key can be reset to the default by the following the steps below.

1. Power off NV10.
2. Set all 4 DIPswitches to the Up position.
3. Apply power (no CCTalk comms).
4. Red LED will now be flashing.
5. Set DIP switches 1 and 2 down.

The code is now reset.

7.8: Extended Interface – USA Serial.

The USA Serial interface is a non-isolated interface serial communications protocol.

There is a single output DATA line from the NV8. There are three control lines, two from the controller "ACCEPT ENABLE" and "SEND" and one from the Validators "IRQ".

Caution:

- Please note that the NV10 works on a +12volt DC power supply.
- The NV10 ground must be connected to the ground of the control system.
- For further details on this protocol please refer to the Series 2000 Interface manual (reference number 20105-002850046-PS)

Connection Details:

| Signal | NV8 |
|-----------------|-----|
| 12v | 15 |
| 0v | 16 |
| ACCEPT ENABLE | 6 |
| SEND | 7 |
| IRQ (INTERUPPT) | 2 |
| DATA | 1 |
| OUT_OF_SERVICE | 3 |

Table 8 - Extended Interface USA Serial

8: Updating Currency and Firmware

Note: Validators are supplied already programmed from the factory. Please skip this section unless the validators need to be re-programmed with a new note or currency.

The NV10 Validator may only be programmed using the NV10 currency download manager or by cloning from a master unit:

8.1: Currency Manager

To use the NV10 Currency Manager Software, which is supplied with a range of currencies. The system will require you to be running a PC Windows 95/98/NT™2000 or XP Professional, Pentium™ (© Microsoft and Intel). 100MHz or faster with a serial port (DA1 kit) or USB port (DA2 kit) and a 12volt dc power supply, to power the Validators (see [Appendix E](#)).

A list of currently supported currencies is maintained on our web site, where new releases can be downloaded. Further details are available from support@innovative-technology.co.uk

How to register for the first time log in, please refer to [Appendix F](#).

8.2: NV10 – NV10 Copy (Cloning)

Overview

There NV10 Bank Note has a facility to copy its programme and settings to another NV10. The 'Master' validator will transmit the currency data and upgrade the slave's firmware. For cloning it is recommended to use the cloning kit 2 (CK2).

Requirements

- Master to have firmware 3.15 or greater
- Cloning Kit 2
- 12V supply.

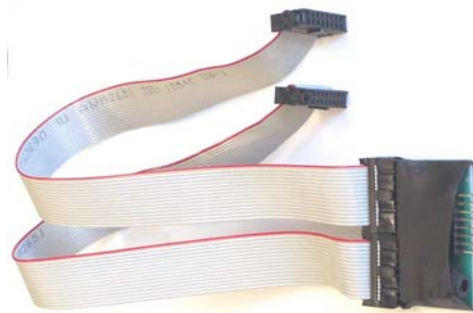

Figure 8 – Cloning Kit 2

Start-up configuration

- Remove power from slave and master units.
- Set DIP switches 3 up and 4 down to select SSP interface mode on both NV10's.
- Using the NV10 cloning kit CK2 or connect the two units together as above (see figure 8).
- Turn on the 12V supply.
- The Master unit will update the slave firmware if the version of the master is greater than the slave. If the master firmware is less than the slave, then the copy process is aborted.
- If the firmware on the master and slave are the same only the currency will be transferred.

8.3: NV10 – NV10 copy process.

- Connect NV10 master to slave using copy adaptor and apply 12V power supply
- Master unit will flash RED and GREEN LED if the connector is configured correctly.
- RED and GREEN on master flash together – attempting to communicate with slave.
- RED and GREEN on master flash alternately - communication established, master waiting for slave to reset.
- If communication has been established and slave has reset then the master will read slave firmware version and decide on next action.
- If the master is not compatible with the slave, Master RED and GREEN LED's will flash alternately at 1-second rate. No further copy action will take place.
- If slave firmware version is greater than master: Master RED and GREEN LED's will flash alternately at 1-second rate. No further copy action will take place.
- If slave firmware version is same as master then master will start to copy currency data to slave.
- If slave firmware version is less than master then master will start to copy firmware data to slave.

Firmware copy:

Caution: If master RED LED changes to slow blink (1 per second) then communication has been lost and copying should be restarted from beginning.

- Master RED LED will blink rapidly during firmware copy (the LED will pause from time to time).
- If master RED LED changed to slow blink (1 per second) then communication has been lost and copying should be restarted from beginning.
- When firmware copy is complete, slave will reset and Master unit will wait to re-establish communications. (LED flashes as at first stage power-up).
- When slave is ready, master will initiate currency data copy.

Currency copy:

Caution: If master RED LED changed to slow blink (1 per second) then communication has been lost and copying should be restarted from beginning.

- Master GREEN LED will blink rapidly during the currency copy process (the LED will pause from time to time).
- When currency copy is complete, Master will show GREEN and RED LED's continuously and slave will reset.
- NV10 – NV10 copy is now complete.

9: Mechanical Installation

The NV10 validator is supplied with the Universal Bezel-PA231 (see figure 9).

9.1: Changing or removing the bezels:

- Push the red Bezel Release Catch in the centre and top of the NV10.
- The bezel can then be unhooked from the 4 locating points on the NV10.
- To refit, hook the bezel onto the bottom 2 locating points and then lift to fit onto the top 2 locating points on the NV10.
- The bezel will 'click' home into NV10 when fitted correctly.

9.2: Fitting the bezel into a machine

Caution

- Ensure there is a clearance around the initial exit (see drg GA334 in [Appendix A](#)) so there is no obstruction to the banknotes as they are being read by the NV10.
- A suitable cash box is needed so that the notes securely store away from the note exit (see [Appendix C](#)), to prevent notes accumulating at the note exit.
- The cash box should form a physical barrier between the initial exit and the note exit.

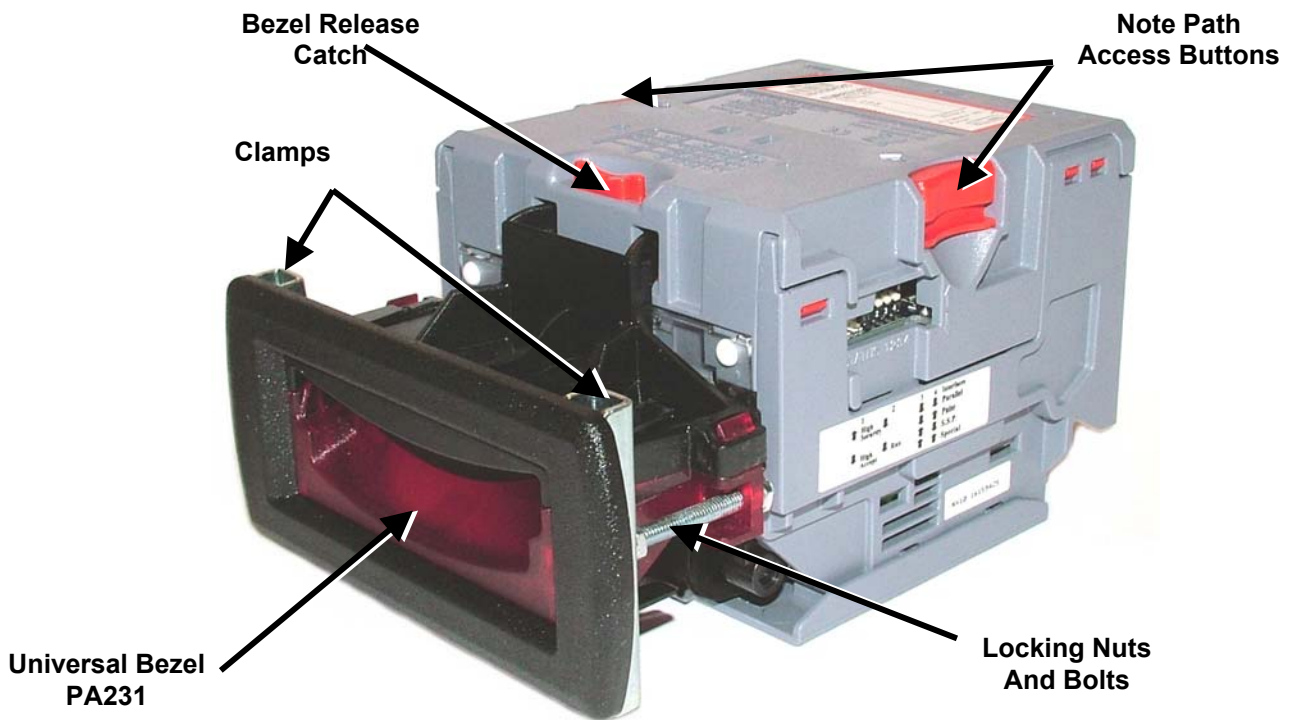

Figure 9 – Bezel and NV10 Installation

- Remove the 4 nuts, 2 metal clamps, star washers and 2 bolts from each side of the bezel as above (see figure 9).
- Place PA231 through the aperture in the door of the machine from the front.
- Fit the two metal clamps and star washers and tighten the nuts onto the bolts (recommended torque 25cN per metre).
- Fit the main bezel assembly onto the bolts with the black part to the top. Fit the star washers and tighten the nuts onto the bolts (recommended torque 25cN per metre).

9.3: Cash Box Interface

It is important that there is sufficient space for the "initial exit" and "final exit" of notes from the NV10 note path, before entry into the cash box/chute without any obstructions (see [Appendix C](#) Figure 17 and Figure 18).

For help on installing the NV10 into a new design please contact
support@innovative-technology.co.uk

10: Routine Maintenance

The NV10 Validator has been designed to minimise any performance variation over time. Much of this is achieved by careful hardware and software design.

However, depending upon the environment the NV10 is installed in it may at some time require cleaning, belt changing or even re-calibration.

CAUTION: DO NOT USE SOLVENT BASED CLEANERS SUCH AS ALCOHOL, PETROL, METHYLATED SPIRITS, WHITE SPIRIT or PCB CLEANER. THIS WILL RESULT IN PERMANENT DAMAGE TO THE VALIDATOR, ALWAYS USE A MILD DETERGENT.

10.1: Cleaning

Remove the NV10 from its bezel. Push the 2 red Note Path Access Buttons on the sides of the NV10 downwards and then inwards towards the body of the NV10 (see figure 9) and lift to expose the note paths, place them on a clean dry surface. The note path will now be exposed for cleaning, (see figure 10).

Carefully wipe the surfaces with a soft lint free cloth that has been dampened with a water and mild detergent solution (i.e. household washing up liquid). Take particular care around all the sensor lenses (see figure 10), ensuring they are clean and dry. Clean any metal debris that may be attached to the magnetic sensor.

If a lens has become badly scratched do not attempt to polish it. Contact ITL for further advise, as there may be damage to the optical properties of the lens.

Caution

When cleaning the "recessed" Front Sensor, use a small soft brush or cotton wool bud.

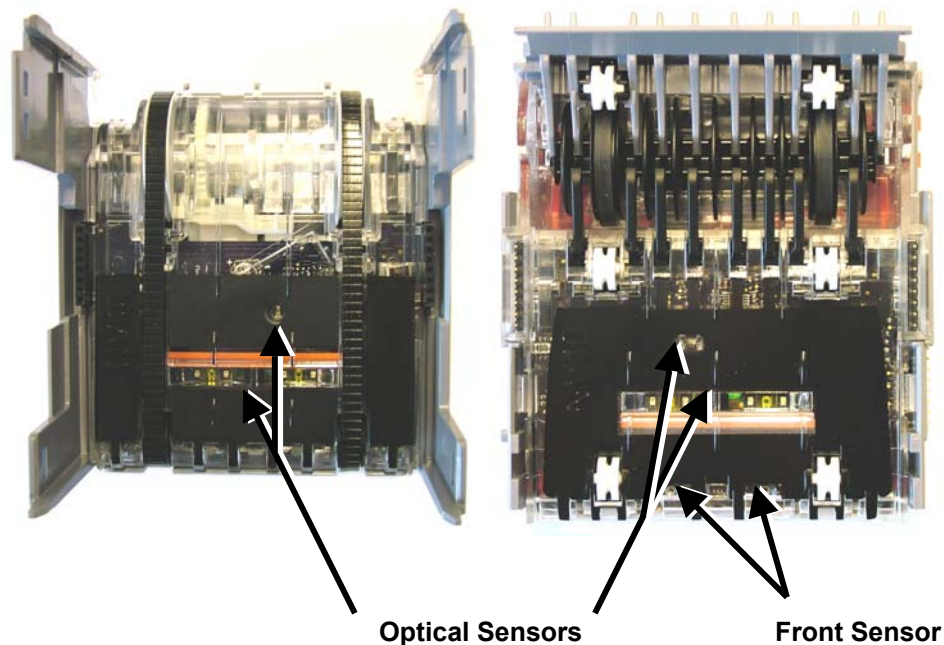

Figure 10 – NV10 Sensors

10.2: Belt Changing

- With the NV10 note paths exposed (see figure 10) place the unit on a clean dry surface.
- Remove the lower cover plate by lifting up the retention catch and carefully sliding it back (see figure 11).
- Push the 2 belt tension springs inwards then slide each belt off the drive unit body, smallest wheels first.
- Replace the belts by fitting them over the drive unit body legs, smallest wheels first.
- Place the lower cover plate into the locating slots (2 each side) pushing forward and down, the plate will “click” confirming correct insertion.
- Connect the upper and lower note path back together.

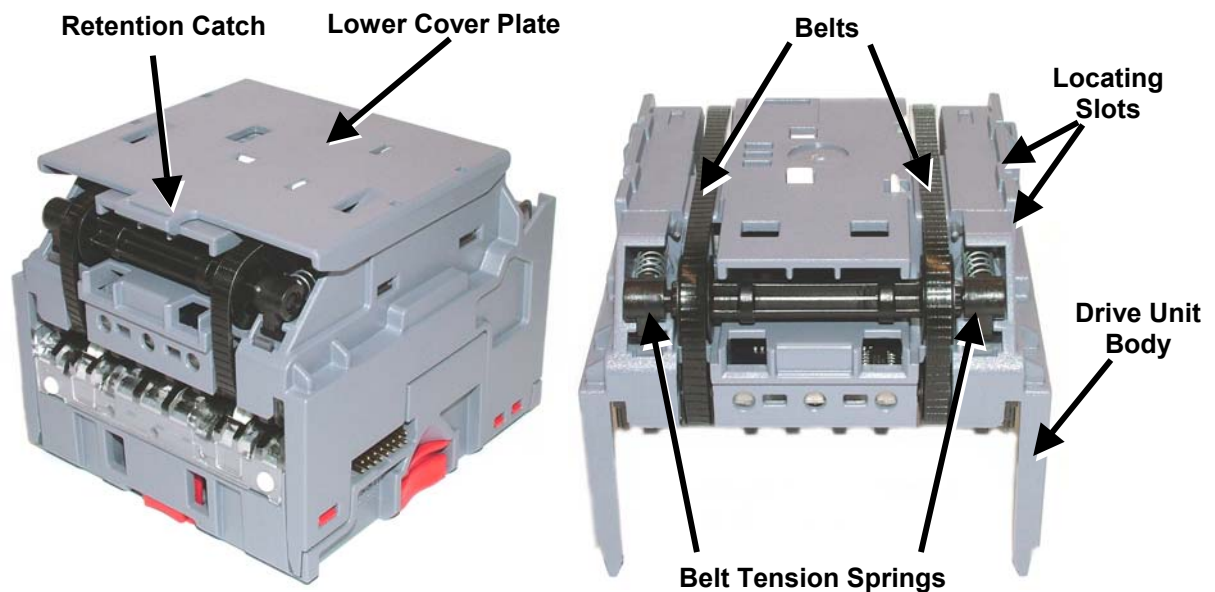

Figure 11 – NV10 Belt Access

11: Fault Finding Analysis

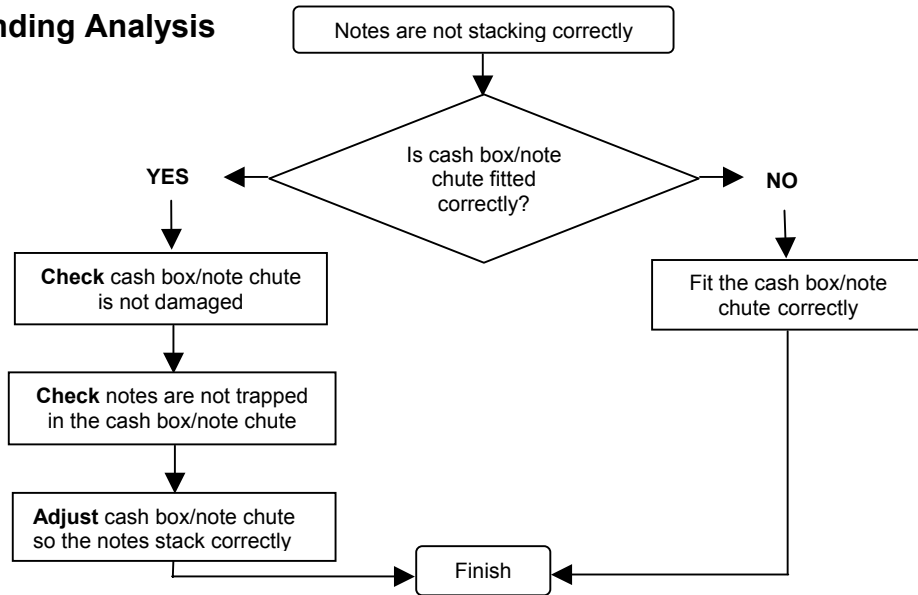

Figure 12 - Notes are not stacking Correctly

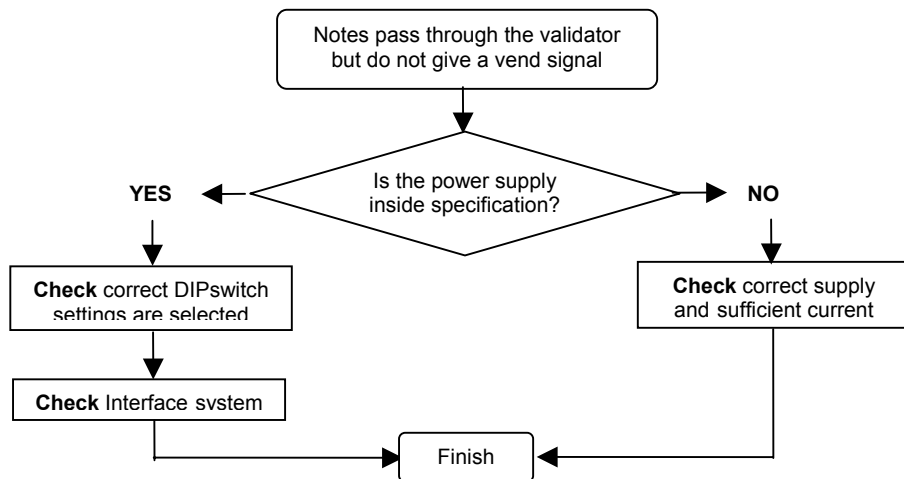

Figure 13 - Notes pass validators with no vend signal

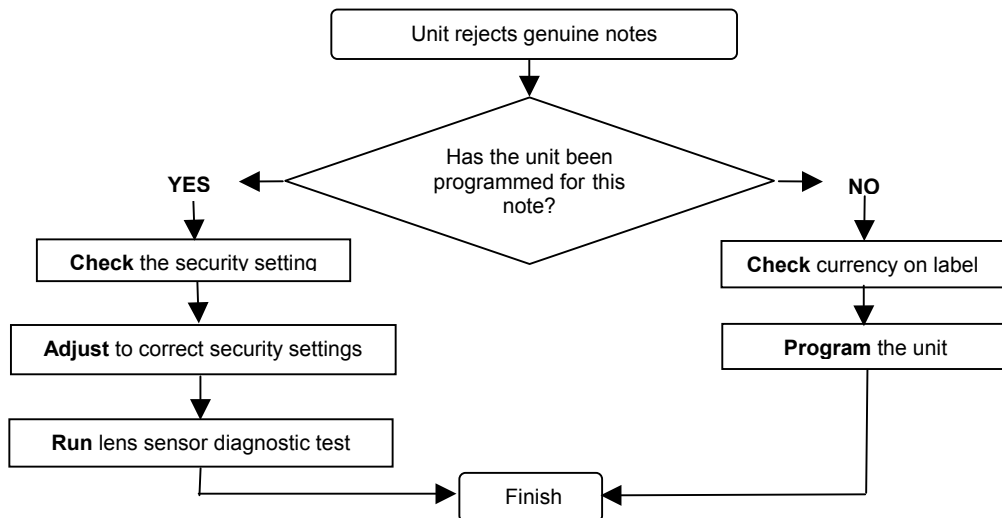

Figure14 - Unit rejects genuine notes

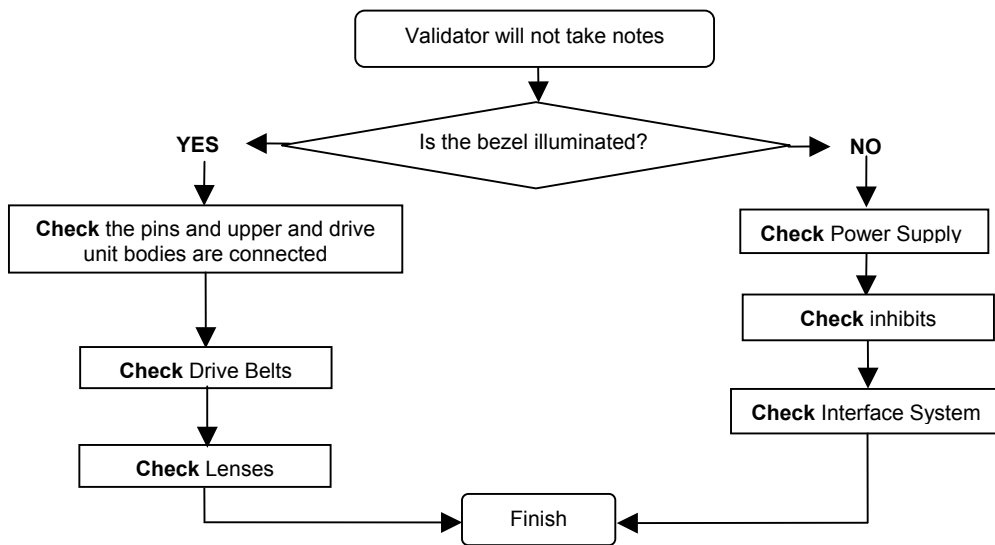

Figure 15 - Validator will not take notes

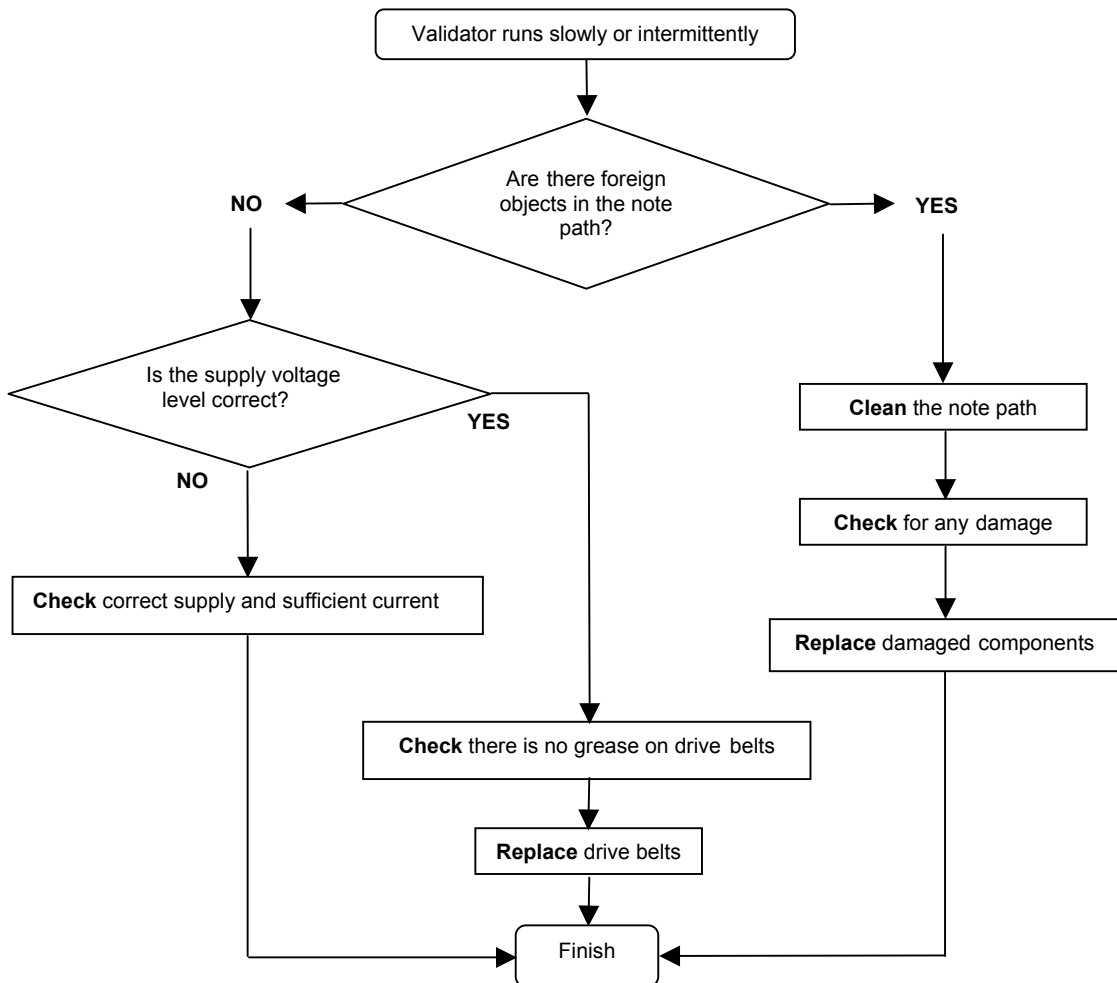

Figure 16 - Validator runs slowly or intermittently

12: Support Tools

The following support tools are available for use with the NV10 Bank Note Validator:

1. PC Currency Manager Software.
2. Downloads from the Innovative Technology Ltd website: www.innovative-technology.co.uk
3. Email Support support@innovative-technology.co.uk

12.1: PC Currency Programming Software.

The NV10 Currency Manager software offers the following functions:

- Program the NV10 Validator by downloading pre-prepared currency data via the serial communications link using the DA1 kit or DA2 kit using the USB link.
- Check the firmware version and currency set already loaded on an NV10 unit.
- Adjust the channel and pulse configuration on a pre-programmed NV10 to your own requirements.
- Download a new version of firmware onto the NV10.
- Use diagnostic functions to check validator operation (firmware version 3.15 and greater only).

The software will run on an IBM compatible Personal Computer with Pentium™ processor or equivalent and requires a DA1 kit fitted to the serial port or DA2 kit fitted to the USB port depending on the operating system that you are using (see [Appendix E](#)).

12.2: Internet Website support

The Innovative Technology Ltd website provides the means to download new and updated currency sets and new versions of firmware for the NV9. Visit www.innovative-technology.co.uk to register your user name and to access the password for further details, updates and technical bulletins, which are also made available.

How to register for the first time log in, please refer to [Appendix F](#).

12.3 : E-mail Support

If the data you require is not available over the Internet Innovative Technology supports an e-mail system to help customers with unusual requirements. The address is support@innovative-technology.co.uk

Appendix B – Extended Bezel

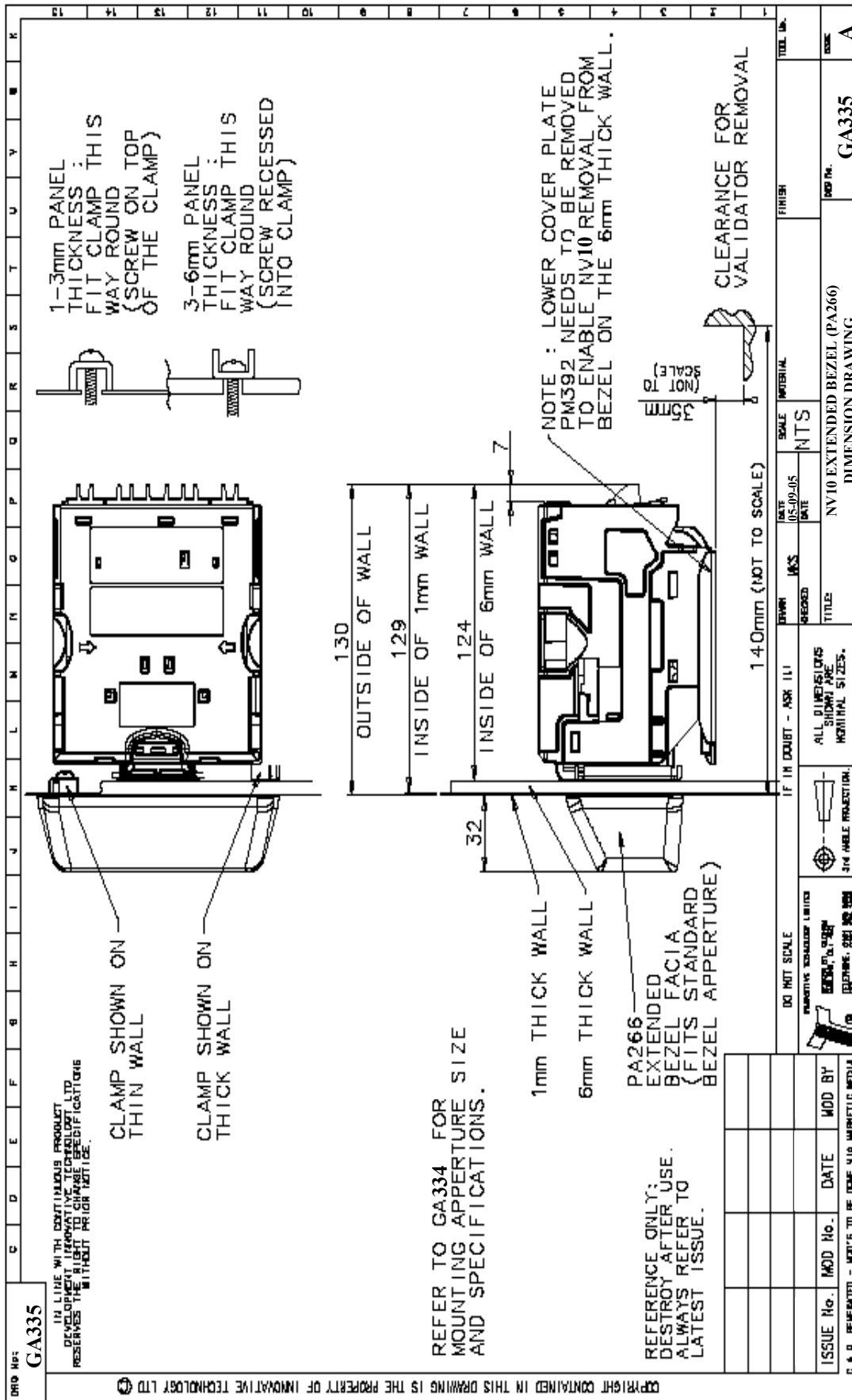

Appendix C – Cash Box Advice

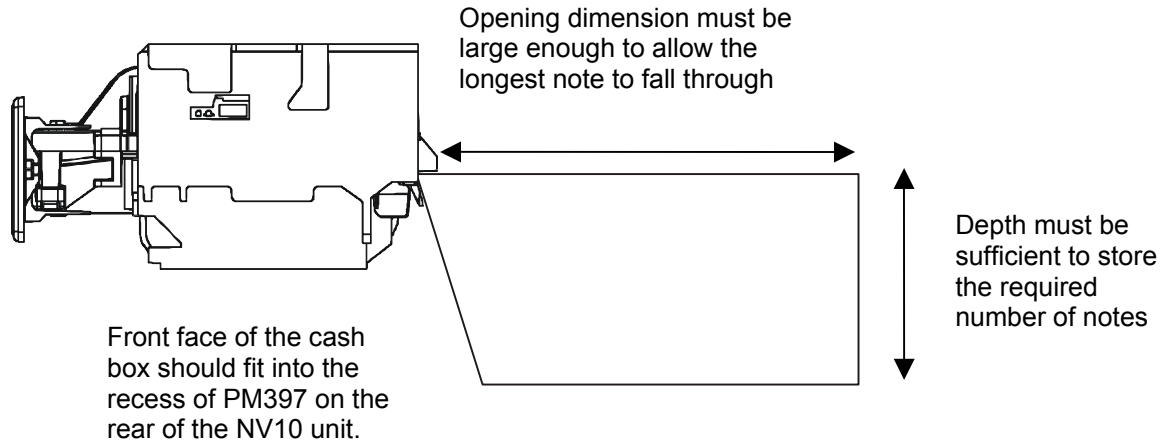

Figure 17 – Cash box mounting location

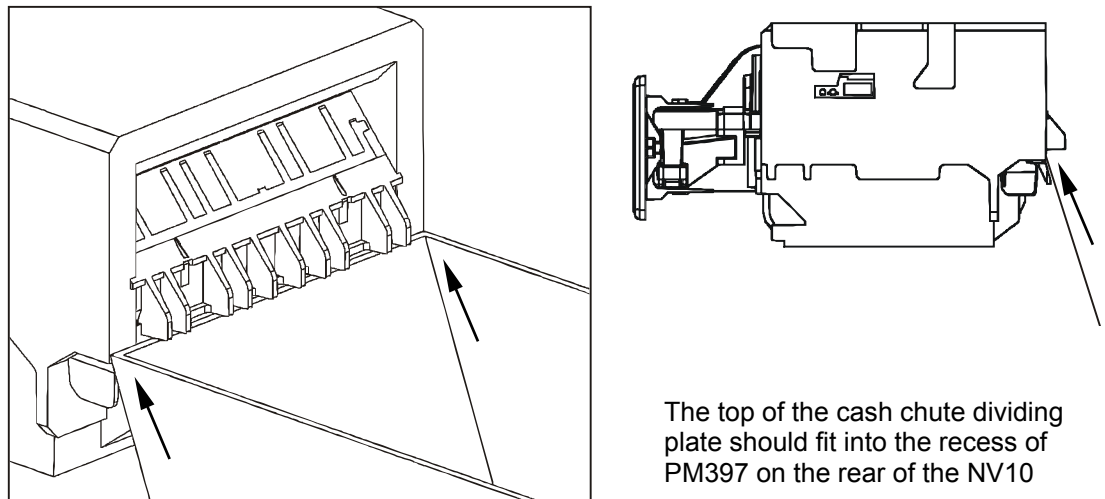

Figure 18 - Dividing plate location for cash chute

Appendix D - ESCROW Control

The NV10 has a single note escrow facility (pin 10). This allows the Validator to hold onto the note once accepted, and then only stack the note in the cash box when the host machine confirms that the Vend operation has been completed. If no confirmation of the Vend is received then the note will be returned to the customer after 30 seconds, (see figure 19).

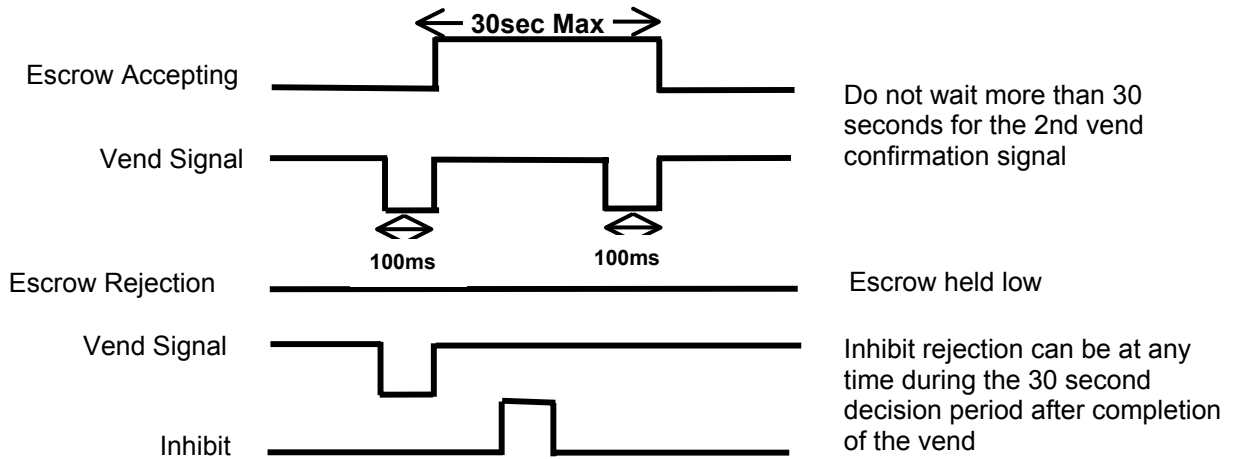

Figure 17 - Escrow Timing Diagram for Parallel Vends

If the host machine itself aborts the transaction by setting the corresponding inhibit input high on pin 10, the note is returned immediately. The sequence of operations is as follows:

1. Pin 10 held low awaiting note insertion.
2. Note inserted. Validator issues a 100ms pulse on the appropriate channel.
3. The host machine initiates vend process.
4. The host machine sets pin 10 high to indicate that it wants the note. If this is not done within 30 seconds the Validator will return the note.
5. The Validator issues a 100ms pulse on the appropriate channel after pin 10 going high to indicate final acceptance of the note. If the signal has not been received within 30 seconds it indicates the customer has forcibly retrieved the note and the vend will be aborted.
6. The vend process is completed.
7. The host machine sets pin 10 low in expectation of the next vend.

The host machine can force the return of the note to the customer by setting the inhibit line high, at any time before the end of the 30 second time-out. For channels above 4, setting all the inhibits high will cause a note reject.

In the event of a note being forcibly removed from the mouth of the NV8 during the 30 second interval, the NV8 will go out of service for 45 seconds.

Note: Escrow Control (SSP mode): Escrow is also possible using the SSP serial Interface. Please refer to SSP Specification GA138 available on the website www.innovative-technology.co.uk.

Appendix E - Interface Tools DA1 - DA2

The DA1/2 Kits are designed for the following:

- Connecting of ITL note validators to a PC to upgrade note data and firmware.
- Testing of NV10 note validators independently of the host machine to confirm the validator is working but the host machine may be inhibiting some of the channels.

The DA1 and DA2 Kit comprise of the following components:

| DA1 | DA2 |
|------------------------------------|----------------------------|
| DA1 adapter board (PA167) | DA2 adapter board |
| NV9 Adapter to Validator cable (C) | USB type-A to Type-B cable |
| ITL Support CD-ROM for DA1 | ITL Support CD-ROM for DA2 |
| Power Cable | DA2 to NV9 cable |
| Installation Guide | Power Cable |
| | Installation Guide |

Connecting a DA1 to a validator and PC

If you are using Windows 95/98/NT™, Pentium™ (© Microsoft and Intel) operating systems connect the DA1 to the validator as shown below (see figure 1), using the 16-way to 5-way connector. The 3.5mm jack plug and 2 banana plugs are used to supply power to the DA1. Connect +12 volts to the red banana plug and GND (0V) to the black plug.

Plug the 9-way D-type connector into the serial port of the PC and note of the number of the port, as this will be needed later for configuring the software. Once the connections have been made install the appropriate software for the validator you are using.

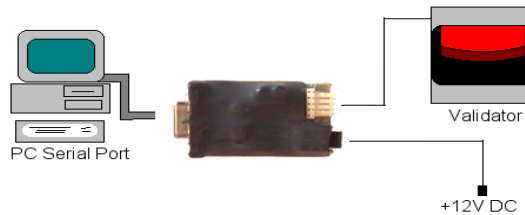

Figure 1 - Connecting DA1 to a NV10 and PC for upgrading

Connecting a DA2 to a validator and PC

If you are using Windows Pentium™ (© Microsoft and Intel) 98, 98SE, 2000, XP Home or XP Professional operating systems, connect the DA2 to the validator as shown below (see figure 2), using the NV10 to DA2 connector. The 3.5mm jack plug and 2 banana plugs are used to supply power to the DA2. Connect +12 volts to the red banana plug and GND (0V) to the black plug.

Plug the USB type A Connector into the USB port of the PC. Once the connections have been made install the appropriate software for the validator you are using.

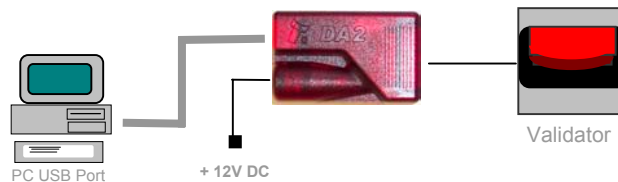

Figure 2 - Connecting DA2 to a NV10 and PC for upgrading

Software Installation

To install the software to upgrade datasets and firmware, insert the CDROM into the PC drive. An installation menu will appear, select the product that you wish to download and select the software you wish to use. Follow the onscreen instruction to complete the installation. Instructions for configuring and using the software you have installed can be found in the online help for that software.

Please contact support@innovative-technology.co.uk, if you require further assistance.

Appendix F – Website Registration

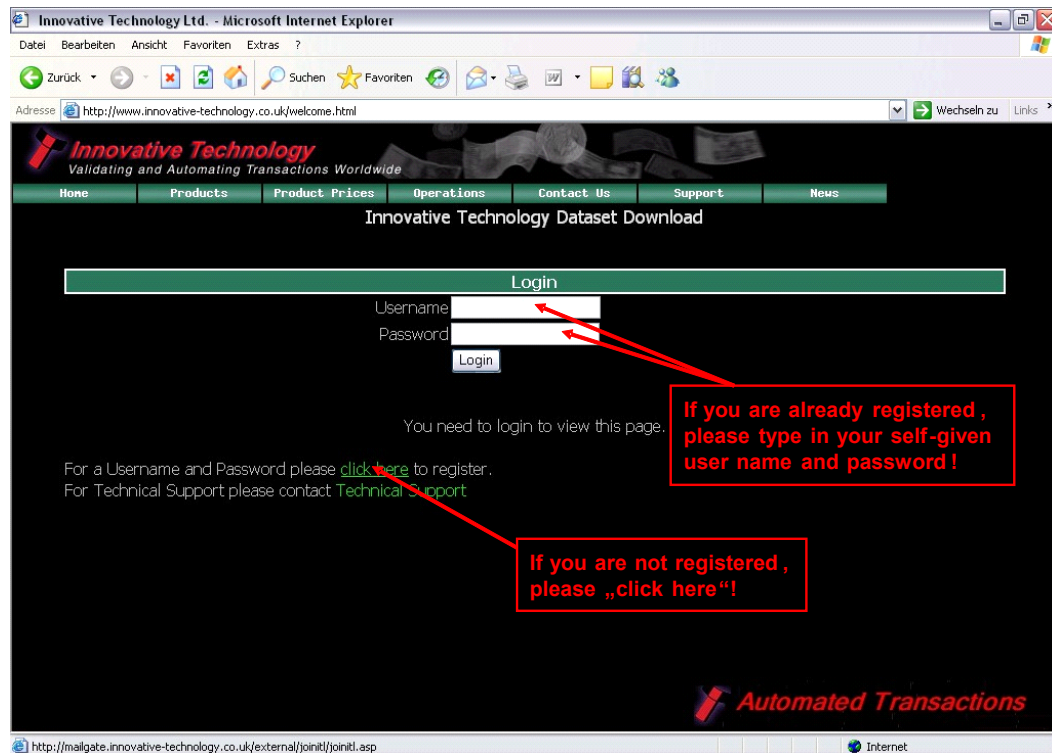
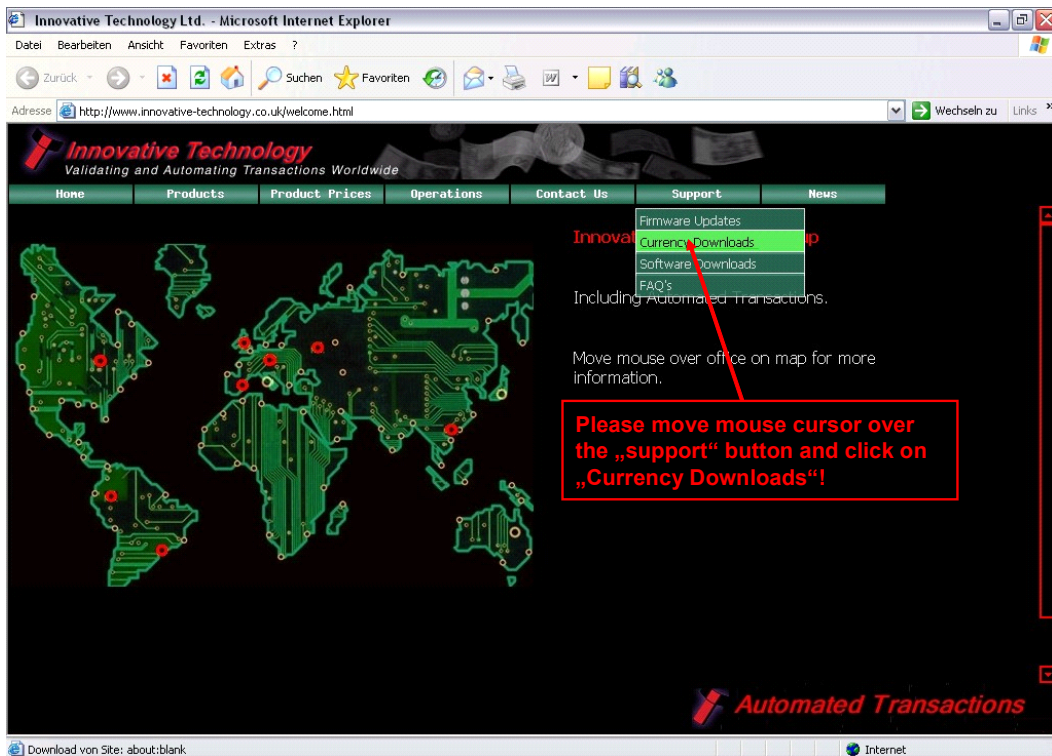

The screenshot shows a Microsoft Internet Explorer browser window displaying the registration page for Innovative Technology. The page title is "Innovative Technology Ltd. - Microsoft Internet Explorer" and the address bar shows "http://www.innovative-technology.co.uk/welcome.html". The website header includes the logo and navigation menu: Home, Products, Product Prices, Operations, Contact Us, Support, News. The main heading reads: "In order to download datasets for Innovative Technology Products you must be a registered user." Below this is a "Registration Details" form with the following fields: Company Name, Email Address, User Name, Job Description (a dropdown menu), Password, and Re-Type Password. A checkbox at the bottom allows users to opt out of receiving technical bulletins via email. A "Register Details" button is located below the form. Red callout boxes with arrows point to specific fields and the button, providing instructions: "Please enter your company name here!" points to the Company Name field; "For your registration we need a valid e-mail address." points to the Email Address field; "Here you can choose a user name which you will need to log in." points to the User Name field; "For a job description you can select one of the listed occupations." points to the Job Description dropdown; "Please enter your self-given password here!" points to the Password field; and "After you filled in all informations, please click on „Register Details“! Approx. 10 mins later your account will be ready for your log in." points to the Register Details button. The footer of the page includes the text "Automated Transactions".